



Digital Mass Flowmeter and Regulator



measuring
•
monitoring
•
analysing

DMS



- Measuring range:
0,1 - 3,7 Nml/min ... 0 - 185 NI/min air
- Accuracy: $\pm 1\%$ of full scale
- p_{\max} : 35 bar; t_{\max} : 50 °C
- Connection:
1/8" - 1/2" compression fitting;
3/8" NPT female;
1/4 VCO; 1/2 VCO;
1/4 VCR; 1/2 VCR
- Sensor casing: stainless steel
- Output: 4 - 20 mA or
0 - 5/0 - 10/1 - 5 V
- Preset for 10 gases

GS



KOBOLD companies worldwide:

AUSTRALIA, AUSTRIA, BELGIUM, BULGARIA, CANADA, CHINA, CZECHIA, FRANCE, GERMANY,
GREAT BRITAIN, HUNGARY, INDIA, INDONESIA, ITALY, MALAYSIA, MEXICO, NETHERLANDS,
PERU, POLAND, REPUBLIC OF KOREA, RUSSIA, SPAIN, SWITZERLAND, THAILAND, TUNISIA,
TURKEY, USA, VIETNAM

KOBOLD Messring GmbH
Nordring 22-24
D-65719 Hofheim/Ts.
Head Office:
+49(0)6192 299-0
+49(0)6192 23398
info.de@kobold.com
www.kobold.com



Description

The new DMS-Series KOBOLD digital mass flowmeters and mass flow regulators have been specially developed for use in gas measurement, where excellent accuracy, high reliability, robust casing, stainless materials and maximum flexibility are important.

The six keys on the control panel and the graphic display make the meter easy to use. The display unit, full scale value of the measuring range, the valve function and the desired value can be set in the simple menu structure. The second analogue output can be selected as 0 - 5 V_{DC}, 0 -10 V_{DC} or 1 - 5 V_{DC}. If the medium changes, the corresponding gas can simply be selected. The memory stores the parameters of ten gases, and they can also be programmed off standard. A password protects the configuration against unauthorised access.

The electrical connection is made with a Sub-D plug. Optionally, the control panel can be connected with a RJ45 plug and socket connection. A special RCA connector is required for the RS232 interface.

Compared with float flowmeters, the DMS mass flowmeter has neither moving parts, nor is it necessary to compensate for changes in operating conditions such as pressure and temperature, because here the mass flow is being measured. The measuring instrument can be installed in practically any position and the simple mechanical construction provides the highest degree of reliability, both with the use of aggressive gases, and also in raw industrial operation.

Application Examples

- Gas monitoring
- Paint lines
- Laminator systems
- Semiconductor industry
- Analysis devices
- Exhaust measurement
- Engineering
- N₂/O₂ -generators
- Boiler controls

Technical Details

Area of application:	suitable for dry, oil-free gases
Measurement system:	bypass capillary system
Measuring range:	see Gas Table
Control range:	2 - 100 % of full scale automatic shut-off from 1.9 %
Gas types:	see Gas Table 10 gases can be set in the menu
Accuracy:	± 1 % of full scale
Repeatability:	±0.2 % of full scale
Standard calibration:	1013.25 mbar abs., 0 °C Option: as per customer specification
Temperature coefficient:	±0.05 % of full scale/°C
Pressure coefficient:	±0.15 % of full scale/bar
Response time	
Time constants:	300 ms
Typically:	2 s (up to display of 98 % of the actual flow-through)
Media and ambient air temperature:	0 ... 50 °C
Max. working pressure:	35 bar (500 psig)
Installation position:	any (state with order), flow-through in the direction of the arrow
Gas proofness:	max. 5 x 10 ⁻⁹ ml/s He
Parts in contact with media:	stainless steel 316 (1.4401) and stainless steel 416 (1.4005) in the regulating valve
Seals:	FPM or Neoprene® (others on request)
Power supply:	15-24 V _{DC} ±10%, 230 mA (DMS-1/2) 24 V _{DC} ±10%, 500 mA (DMS-5) 24 V _{DC} ±10%, 800 mA (DMS-6)
Ripple:	max. 100 mV (peak-peak)
Analogue output 1:	4-20 mA (max. 500 Ω)
Analogue output 2:	0-5 V _{DC} , 0-10 V _{DC} , 1-5 V _{DC} (Load min. 1000 Ω)
Digital output:	RS-232 interface
Desired value (only regulator):	4 - 20 mA, 0-5V _{DC} , 0-10V _{DC} , 1-5V _{DC}
Display:	graphic LC display, 47 x 26 mm
Settings:	via 6 keys gas type, output 2, end value, units, desired value, valve function, password
Electrical connection:	15-pole D-Sub plug including mating plug with 3 m cable, RJ45 for remote control unit with display, mini RCA connection (RS 232)
Protection:	IP 21
Weight:	DMS-1: approx. 0.8 kg DMS-2: approx. 1.4 kg DMS-5: approx. 0.9 kg DMS-6: approx. 2.5 kg



Gas table

Gas	Max. flow-through [NI/min]	
	L-Body	M-Body
Air	50	185
Argon Ar	72.5	270
Carbon dioxide CO ₂	37	136
Carbon monoxide CO	50	186
Methane CH ₄	36	140
Helium He	72.7	260
Hydrogen H ₂	50	185
Oxygen O ₂	50	185
Nitrogen N ₂	50	185
Nitrous oxide N ₂ O	35.5	132

Order Details (example: **DMS-1 01 C1 F 02 30**)

Model	Measuring range	Connection	Seal	Display	Electrical connection	Options	
DMS-1 = meter (L-Body) DMS-5 = regulator (L-body)	00 = 0,1...3,7 Nml/min 01 = 0...10 Nml /min 02 = 0...20 Nml /min 03 = 0...50 Nml /min 04 = 0...100 Nml /min 05 = 0...200 Nml /min 06 = 0...500 Nml /min 07 = 0...1 NI/min 08 = 0...2 NI /min 09 = 0...5 NI /min 10 = 0...10 NI /min 11 = 0...20 NI /min 12 = 0...50 NI /min 99 = special calibration	C1 = 1/8" compression fitting C2 = 1/4" compression fitting C3 = 3/8" compression fitting C4 = 1/2" compression fitting K1 = 6 mm compression fitting K2 = 10 mm compression fitting K3 = 12 mm compression fitting N2 = 1/4 NPT female N3 = 3/8 NPT female V2 = 1/4" VCO face seal V4 = 1/2" VCO face seal W2 = 1/4" VCR front face metal seal ring W4 = 1/2" VCR front face metal seal ring	F = FPM N = Neo-prene® Y = special seal	02 = without display D2 = with display R2 = Remote control/ Remote version	3 = 24 V _{DC} / 15 pol. D-Sub incl. plug with 3 m cable 5 = 15-24 V _{DC} / 15 pol. D-Sub incl. plug with 3 m cable (meter, DMS-1 / 2)	L = without G = other gas selection list	
	DMS-2 = meter (M-body) DMS-6 = regulator (M-body)						11 = 0...20 NI /min 12 = 0...50 NI /min 13 = 0...100 NI /min 14 = 0...185 NI /min 99 = special calibration

Please state the exact operating conditions (gas types, flow volume, pressure, temperature, installation position etc.) when ordering. Suitable wall power supply 100 - 240 V_{AC} / 24 V_{DC} - 500 mA with order number: **ZUB-SNT 035L** (not suitable for DMS-6).

Connection	Measuring range
C1 = 1/8" compression fitting	up to 5 NI /min
C2 = 1/4" compression fitting	up to 30 NI /min
C3 = 3/8" compression fitting	up to 185 NI /min
C4 = 1/2" compression fitting	all
K1 = 6 mm compression fitting	up to 30 NI /min
K2 = 10 mm compression fitting	up to 185 NI /min
K3 = 12 mm compression fitting	all

Connection	Measuring range
N2 = 1/4 NPT female	up to 185 NI /min
N3 = 3/8 NPT female	all
V2 = 1/4" VCO face seal	up to 30 NI /min
V4 = 1/2" VCO face seal	all
W2 = 1/4" VCR front face metal seal ring	up to 30 NI /min
W4 = 1/2" VCR front face metal seal ring	all

Pressure loss for flowmeter

Flow rate [NI/min]	L-Body		M-Body
	[¼"]	[⅜"]	⅜" or ½"
0.037	24.5 mbar	N/A	N/A
0.1	24.5 mbar	N/A	N/A
0.5	24.5 mbar	N/A	N/A
1	25.4 mbar	N/A	N/A
10	31.7 mbar	28.6 mbar	N/A
20	45.7 mbar	32.7 mbar	34 mbar
30	N/A	40.9 mbar	34 mbar
40	N/A	53.3 mbar	34 mbar
50	N/A	68.8 mbar	34 mbar
100	N/A	N/A	68,8 mbar
150	N/A	N/A	136 mbar
200	N/A	N/A	204 mbar

N/A = not applicable

Minimum pressure differential for regulator*

Flow rate [NI/min]	L-Body		M-Body
	[¼"]	[⅜"]	⅜" or ½"
0.037	68 mbar	N/A	N/A
0.1	68 mbar	68 mbar	N/A
1	102 mbar	87 mbar	N/A
10	408 mbar	258 mbar	N/A
20	816 mbar	449 mbar	68 mbar
30	1020 mbar**	639 mbar	82 mbar
40	2040 mbar**	830 mbar	110 mbar
50	2720 mbar**	1020 mbar	136 mbar
100	N/A	N/A	340 mbar
150	N/A	N/A	680 mbar
200	N/A	N/A	1020 mbar

* Tested at 21 °C, output: ambient pressure

** We recommend a larger fitting for these flow volumes

Dimensions

DMS-1... /DMS-5...

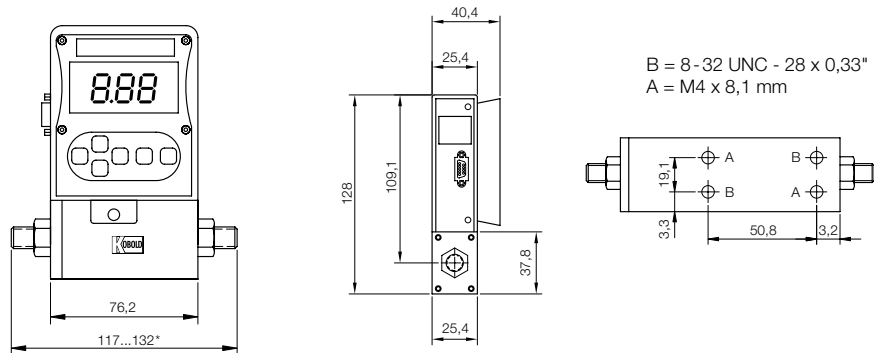

* Depending on connection fitting

DMS-2...

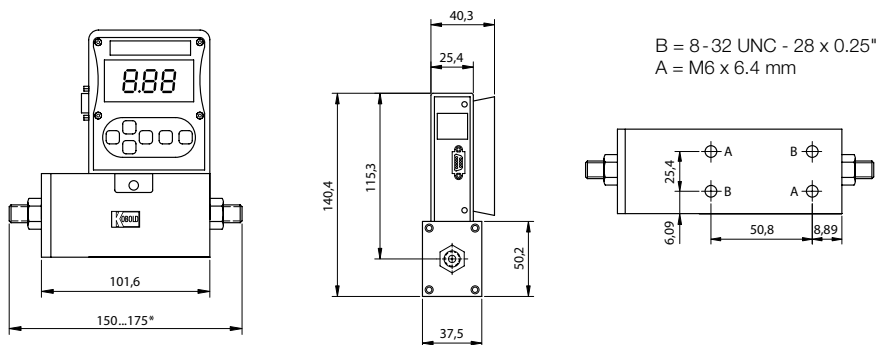

* Depending on connection fitting

DMS-6...

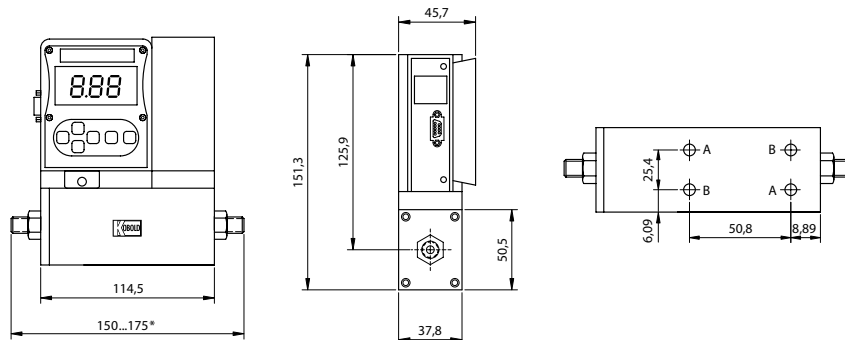

* Depending on connection fitting