



Positive Displacement Oval Gear Flow Meter

for low and high viscous liquids



measuring
•
monitoring
•
analysing

DON



- Measuring range:
0.5 ... 36 l/h und 150 ... 2500 l/min
- Viscosity range: up to 1000 cP (standard)
(higher with special cut rotors)
- Accuracy: $\pm 0.2 \dots 1\%$ of reading
- Material: aluminium or stainless steel
- p_{\max} : 100 bar; t_{\max} : 150 °C
- Pulse output, LCD display, 4...20 mA,
alarms, mechanical register



S4

KOBOLD companies worldwide:

AUSTRALIA, AUSTRIA, BELGIUM, BULGARIA, CANADA, CHINA, CZECHIA, FRANCE, GERMANY, GREAT BRITAIN, HUNGARY, INDIA, INDONESIA, ITALY, MALAYSIA, MEXICO, NETHERLANDS, PERU, POLAND, REPUBLIC OF KOREA, RUSSIA, SPAIN, SWITZERLAND, THAILAND, TUNISIA, TURKEY, USA, VIETNAM

KOBOLD Messring GmbH
Nordring 22-24
D-65719 Hofheim/Ts.
Head Office:
+49(0)6192 299-0
+49(0)6192 23398
info.de@kobold.com
www.kobold.com

Principle of Operation

Positive Displacement Oval Gear Flow Meters are categorised as positive displacement flow technology. When liquid flows through this type of positive displacement flowmeter, two oval geared rotors measure a constant volume per rotation within a precisely machined measuring chamber. With each rotation, a constant volume of liquid is measured. The rotation of the oval wheels is sensed via magnets embedded within the rotors. These magnets transmit a high resolution pulse output. The output signal can be processed externally via a remote display controller or PLC or via a variety of output/display options available as accessories attached to the flowmeters.

Operation:

Liquid travels around the crescent shaped chambers created by the rotational movement of the rotors

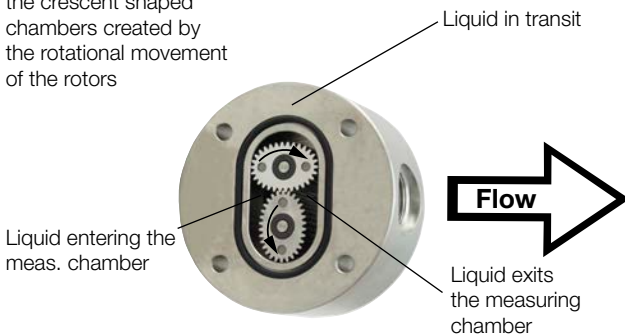

The positive displacement flow technology allows for precise flow measurement of most clean liquids regardless of the media conductivity. Other liquid properties also have a minimal effect on the performance of this type of meter. Flow profile conditioning is not required as with alternative flow technology options making oval gear installations simple to install in tight spaces and at an economical price.

Areas of Application

For all viscous, non abrasive clean liquids like:

- Petroleum ● Oil ● Chemicals
- Grease ● Fuels ● Ink etc.
- Pastes

Stainless steel flowmeters are suited to most products and chemicals and aluminium meters are suitable for fuels, fuel oils & lubricating liquids.

Technical Details

Material

DON-1/3	
Body:	aluminium
Oval wheels:	PPS GF30/PTFE, PEEK
Axes:	stainless steel 1.4404
DON-2/4	
Body:	stainless steel 1.4404 DON-x04 ... DON-x15 stainless steel 1.4404 / 1.3955 DON-x20 ... DON-x60
Oval wheels:	stainless steel 1.4404 DON-x04 ... DON-x40 stainless steel 1.3955 DON-x45 ... DON-x60
Bearing:	carbon graphite
Axes:	stainless steel 1.4404
DON-8/9	
Body:	stainless steel 1.4404 DON-x04 ... DON-x15 stainl. steel 1.4404 / 1.3955 DON-x20 ... DON-x60
Oval wheels:	PPS GF30/PTFE, PEEK
Axes:	stainless steel 1.4404
O-rings:	medium temperature FKM: -20 ... +150 °C NBR: -20 ... +100 °C FEP-O-seal: -15 ... +120 °C (FEP-O-seal, FEP encased, with solid core EPDM/FKM, only for DON-x04 ... x40) Fluoroprene® -20 °C ... +150 °C acc. to regulation (EC) No. 1935/2004
Cover for cable connection:	polyamide PA6 GF35 UL94 HB/VO stainless steel 1.4404 (optional)
Magnet encapsulation:	DON-x04 ... DON-x10 PEEK DON-x15 ... DON-x60 st. st. 1.4404



Material screws

For aluminium housing:
 stainless steel (standard)
 steel, coated with GEOMET® 321 (DON-A25)

For stainless steel housing:
 stainless steel (standard)
 steel, coated with GEOMET® 321 (optional) for higher pressure rating (see order details)

Accuracy (under reference conditions*):
 ± 3 % of reading 0.5 - 3.6 l/h (DON-x04)
 ± 1 % of reading 3.6 - 36 l/h (DON-x04)
 ± 1 % of reading (DON-x05...DON-x15)

SS-rotors:
 ± 0.5 % of reading (DON-x20...DON-x60)
 ± 0.2 % of reading (DON-x20...DON-x60; with optional Z3/3A-electronics based on linearisation function)

PPS-rotors:
 ± 1 % of reading (DON-x20...DON-x60)
 ± 0.5 % of reading (DON-x20...DON-x60; with optional Z3/3A-electronics based on linearisation function)
 ± 1 % of reading (option M) (better accuracy for higher viscosities on request)

Additional max. inaccuracy for analogue outputs 4-20 mA:
 +/- 0.15% full scale

Repeatability:
 typ. ± 0.03 %

Protection class:
 IP 66/67 (IP 65 for M4)

Medium temp.:
 -20 °C... +80 °C for options Lx, Zx, M4, DON-1/3/8/9 and -20 °C... +120 °C for DON-2/4 with pulse output and options Zx with cooling fins
 -20 °C... +150 °C option T0 and cooling fins
 -20 °C... +80 °C for models with PPS/PEEK rotors

Ambient temp.:
 -20 °C... +80 °C, option M4 0 °C... +60 °C

Cable entry:
 M20x1.5, 1/2" NPT adapter

ATEX-approval

Mechanical explosion protection:
 Ⓜ II 2G Ex h IIC T4/T3 Gb

Options 1A/2A/3A/5A:
 Intrinsic safety Ⓜ II 2G Ex ia IIC T4 Gb (-20 °C ≤ Ta ≤ +60 °C)

Options HE,DE,BE,KE,GE,LE:
 Flameproof enclosure Ⓜ II 2G Ex db IIC T4/T6 Gb Ⓜ II M2 Ex db I Mb

Options HA,DA,BA,KA,GA:
 Intrinsic safety Ⓜ II 3G Ex ic IIC T4/T3 Gc

IECEX-approval

Options HE,DE,BE,KE,GE,LE:
 Flameproof enclosure Ex db IIC Ex db I Mb

Maximum Pressure (threaded version)

Model	Maximum pressure (bar)			
	DON-1/3	DON-2/4/8/9	DON-1.. (Option-M4)	DON-2/8 (Option-M4)
DON-x04	64	100	-	-
DON-x05			-	-
DON-x10			-	-
DON-x15	70*	100	-	-
DON-x20		60*	40	40
DON-x25				
DON-x30	40	50	30	30
DON-x35				
DON-x40	16	16	16	16
DON-x45				
DON-x50				
DON-x55				
DON-x60				

With flanges, maximum pressure rating as above or as per flange rating, whichever is lower

* Max. pressure rating of 100 bar possible with steel screws (see order details)

Noise Level (in dB) at Full Scale

Size	PPS-Oval Wheels	Stainless Steel-Oval Wheels
x25	83	91
x30	84	93,1
x35	83,5	95
x40	85,4	96
x45	87,5	98
x50	86,1	99,4
x55	86,1	98,1
x60	85	99

Recommended Filter (for example model MFR-DO...)

DON-x04 ... DON-x15 < 75 µm micron (200 mesh)
 DON-x20 ... DON-x35 < 150 µm micron (100 mesh)
 DON-x40 ... DON-x60 < 350 µm micron (45 mesh)

* Reference conditions: x10...x60 (calibration oil 4.6 cSt, 25 °C, 1 bar)
 x04/x05 and x15 for high viscosities (calibration oil 10 cSt, 20 °C, 5 bar)
 Accuracy data is valid for given viscosities and higher.



Pulse Output (H0/HE/HA)

Options H0/HE/HA are equipped with a Reed switch pulse output and a Hall sensor pulse output.

Reed switch pulse output

The reed switch output is a two wire normally open SPST voltage free contact ideal for installations without power or for use in hazardous area locations when Intrinsically Safe (I.S.) philosophy is adopted.

Note: when using the reed switch output the liquid temperature must not change at a rate greater than 10°C per minute.

Average switching life of reed contact (MTTF):

max. load (30 V/10 mA) 5×10^5 switching cycles

max. load (<5 V/10 mA) 5×10^8 switching cycles

Switching capacity: max. 30 V_{DC}, max. 20 mA

Hall sensor pulse output

With this signal output, a Hall Effect sensor is combined with an active push-pull output. The electrical connection is provided in 3-wire version. The output is actively switched either to +Vs or to ground. The external supply voltage is 8...30 V_{DC}. No additional external circuit is required (e.g pull up resistor). The high signal is approximately equal to the supply voltage +Vs and the low signal is approximately 0 V. The electrical load may optionally be connected to the supply voltage or to GND.

Maximum output current (current source or sink): 100 mA (short circuit protected).

Hall sensor pulse output (...HU)

Like option H0, however with following deviations:

- (i) no push-pull output - only NPN output
- (ii) supply voltage 5 - 30 V_{DC}

Hall sensor pulse output (...B0/BE/BA)

Like options H0/HE/HA, however with bipolar sensors and alternating polarised magnets. This option is used for pulsating flows, but it is not equipped with Reed switch and has halved K-factor as compared to H0/HE/HA.

High-resolution Hall sensor pulse output, (...G0/GE/GA, ...K0/KE/KA)

Like options H0/HE/HA; model DON-x05 and DON-x10 can be supplied with four times the count of pulses per liter (...G0/GE/GA) and models DON-x05, DON-x10 and DON-x15 with double amount of pulses (K0/KE/KA) (see table «Output Pulse Resolution» on the following pages).

Quadrature hall effect pulse output (...D0/DE/DA)

DON instrument with option D0/DE/DA is provided with two independent Hall sensors. The two Hall effect sensors are arranged to give separate outputs out of phase with one another.

The QUAD output is mostly suitable for custody transfer with redundant signal or for detecting bidirectional flows (detection of flow direction).

Maximum output current per channel (current source or sink): 100 mA (short circuit protected).

Option L0/LE

The options L0 and LE (Exd) are available with loop powered 4-20 mA output. The loop is supplied with an external power supply 16...32 V_{DC}. The maximum resistance of the series loads (PLC analogue input/display electronics) depends on the magnitude of the supply voltage and can be calculated as:

$$\text{Max. load [Ohm]} = (+Vs - 9 V_{DC}) / 0.02 \text{ A } [\Omega]$$

$$\text{Example: } +Vs = 32 V_{DC} \Rightarrow \text{max. load} = 1150 \Omega$$

$$+Vs = 16 V_{DC} \Rightarrow \text{max. load} = 350 \Omega$$

The load can be inserted at any point in the current loop observing correct polarity.

Mechanical totaliser (...M4)

The flowmeters type DON-x20... up to DON-x60... are available with a 4-digit resettable mechanical totaliser and indication of accumulated total value. The motion of the rotors is transmitted to the mechanical register totaliser via an interfacing reduction gear train and dynamic seal assembly.

Option M4 is available for DON-x20...x40 for volume units litre and gallon, and for DON-x45...x60 for volume units 10 litres and 10 gallons.

Body material: enamelled die-cast aluminium, powder-coated

Protection: IP65

Ambient temp.: 0...+60°C

Medium temp.: -20...+80°C



Electronic with LCD Display

Model	..Z1	..Z2	..Z3	..Z5	..ZE	..ZB	..1A	..2A	..3A	..5A
Function	dual totaliser	dosing unit	rate/counter				dual totaliser	dosing unit	rate/counter	rate/counter
Power supply										
External	5 - 28 V _{DC}	12 - 28 V _{DC}	5 - 28 V _{DC}		9 - 28 V _{DC}	-	U _i = 28 V I _i = 100 mA P _i = 0.7 W			
Battery operation (output deactivated) ²⁾	yes	no	yes	no	yes	yes	yes	no	yes	no
Battery included in shipment ³⁾	yes	-	yes	-	yes	yes	yes	-	yes	-
LCD display										
Selectable units	yes	yes	yes	yes	yes	yes	yes	yes	yes	yes
Decimal point	yes	yes	yes	yes	yes	yes	yes	yes	yes	yes
Accumulative total	yes	yes	yes	yes	yes	yes	yes	yes	yes	yes
Resettable total	yes	yes	yes	yes	yes	yes	yes	yes	yes	yes
Linearisation	yes	no	yes	yes	yes	yes	yes	no	yes	yes
Rate display	yes	yes	yes	yes	yes	yes	yes	yes	yes	yes
Backlighting	yes	yes	yes	yes	yes	no	no	no	no	no
Input										
Sensors	Hall sensor/ reed switch									
Outputs										
4-20 mA	no	no	yes	yes	no	no	no	no	yes	yes
Flow rate alarm min./max.	no	no	NPN/PNP/PP	NPN/PNP/PP	no	no	no	no	no	with solid-state relay board
Batch end & control	no	yes	no	no	no	no	no	yes	no	no
Pulse outputs	no	no	PP	PP	PP	no	no	no	no	with solid-state relay board
2 x SPDT relays ¹⁾	no	yes	no	yes	no	no	no	with solid-state relay board	no	
Installation										
IP65	yes	yes	yes	yes	IP66/67	IP66/67	yes	yes	yes	yes
Cable entries	M20x1.5 / ½" NPT									
Medium temperature (Option: max. +120 °C)	-20...+80 °C									
Ambient temperature	-20... +80 °C					-20... +60 °C				
Housing material	PA6 GF35 UL94 HB/VO/PC UL94 V-2									
ATEX approval	no					yes				

¹⁾ Replaces solid state outputs, for details see data sheet ZOK

²⁾ Battery operation only applicable with the reed switch sensor of electronics options H0/HE/HA

³⁾ Options Z5, Z6, Z7, Z8 and Z9 are shipped without batteries



DON Pressure Drop Curves versus Viscosity

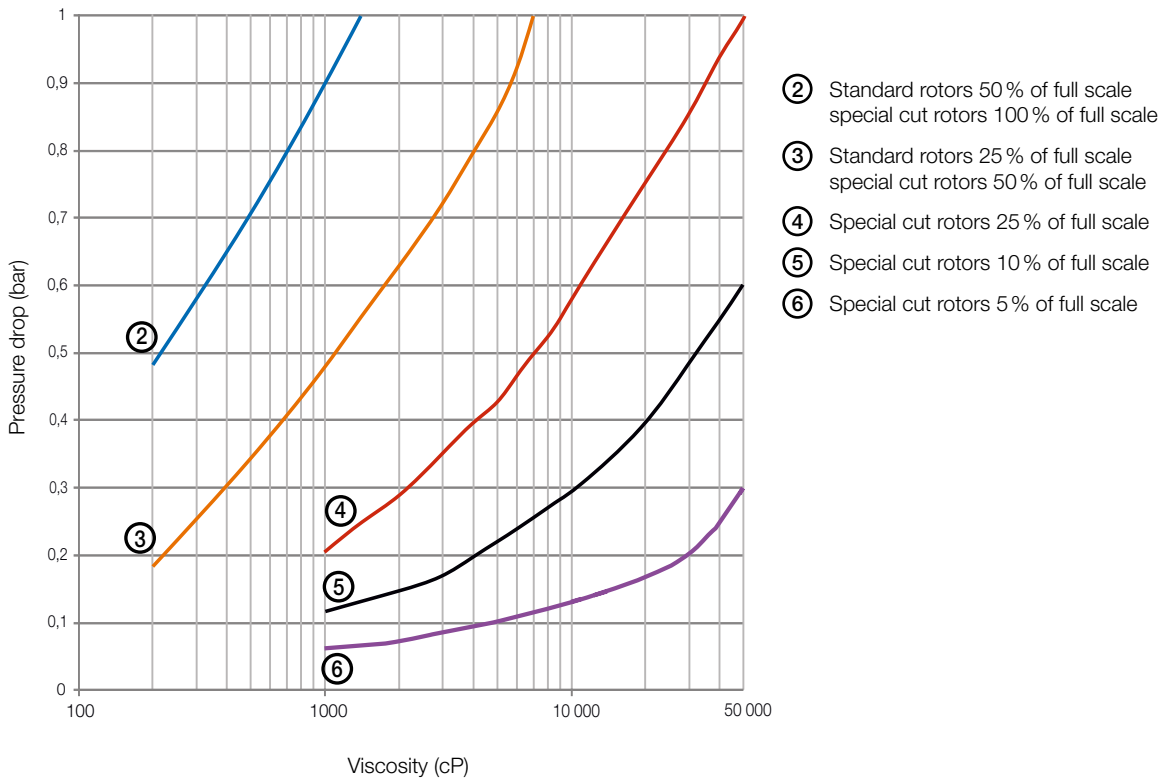
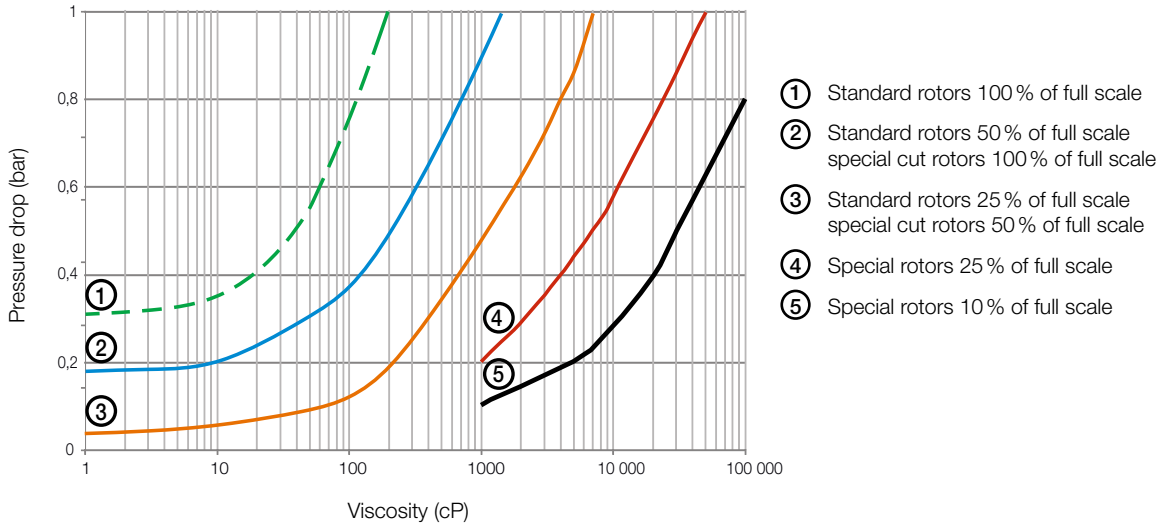

Pressure drop limit versus flowrate

The curves above represent the pressure drop for standard cut oval rotors. Special cut rotors of DON-3/4/9 have alternate tooth relieve which effectively reduces the pressure

drop by 50%. When sizing a meter, be sure your selection falls **below the 1 bar maximum allowable pressure drop line on the graph.**



Maximum Flowrate Multiplier (for higher viscosities)

Viscosities (cP)	Standard rotor	Special cut rotor
≤ 1000	1	1
≤ 2000	0.5	1
≤ 4000	0.42	0.84
≤ 6000	0.33	0.66
≤ 8000	0.25	0.5
≤ 30000	0.15	0.3
≤ 60000	0.12	0.25
≤ 150000	0.1	0.2
≤ 250000	0.05	0.1
≤ 1000000	0.025	0.05

Special cut rotors for higher viscosities

For viscosity > 1000 cP, special cut rotors of DON-3/4/9 should be used to reduce pressure drop. This applies to DON-x15 and larger sizes. For higher viscosities, the flowmeter max. flowrate is de-rated according to the attached chart. At viscosities <1000 cP these special rotors are less accurate.

Example: DON-x25 measuring oil at 8000 cP, max. flow 150 l/min x 0.5 = 75 l/min new maximum flow rate.

Output Pulse Resolution

Model	Measuring range [l/min]	Pulse/litre					
		Reed switch Hx	Hall sensor Hx	Hall sensor Bx	Quadr. hall sensor Dx	Hall sensor, high-resolution Gx	Hall sensor, high-resolution Kx
DON-x04	0.5 - 36 l/h	2670	2670	-	2670	11320	5340
DON-x05	0.5 - 36 l/h	2670	2670	-	2670	11320	5340
DON-x10	2 - 100 l/h	1062	1062	-	1062	4248	2124
DON-x15	15 - 550 l/h	351	702	351	702	-	1404
DON-x20	1 - 40	82	163	82	163	-	-
DON-x25	10 - 150	26	104	26	52	-	-
DON-x30	15 - 250	13.5	55	13.5	27	-	-
DON-x35	30 - 450	6.4	25.5	6.4	13.5	-	-
DON-x40	50 - 580	4.9	19.6	4.9	9.8	-	-
DON-x45	35 - 750	2.57	10.3	2.57	5.15	-	-
DON-x50	50 - 1000	1.5	5.9	1.5	3	-	-
DON-x55	75 - 1500	1.05	4.2	1.05	2.1	-	-
DON-x60	150 - 2500	0.56	2.3	0.56	1.15	-	-

The values in above mentioned table are only approximate guidelines. The actual value for pulse rate can deviate from the values in this table and is mentioned in calibration certificate delivered with the flowmeter.



Positive Displacement Oval Gear Flow Meter Model DON

Order Details (Example: DON-105H R1 1 L0 M 0)

Measuring range	Housing material ⁴⁾			Connection	O-Ring Material	Electronics	Cable entry	Option
	Aluminium with PPS/PEEK ¹²⁾ Rotor	Stainless steel	St. steel with PPS/PEEK ¹²⁾ Rotor					
0.5 - 36 l/h	DON-104H	DON-204H	DON-804H	R1 = G 1/8 N1 = 1/8" NPT	1 = FKM 3 ¹⁴⁾ = FEP-O-ring 4 = NBR 5 ¹³⁾ = Fluoro-prene ⁹⁾ 9 = special materials (not for ATEX)	H0 = Pulse output Hall sensor (Push/Pull)/Reed switch HU ¹⁴⁾ = Pulse output Hall sensor (NPN)/Reed switch, supply 5-30 V _{DC} B0 ³⁾ = Pulse output Hall sensor (Push/Pull) for pulsating flow T0 ⁹⁾ = Pulse output Hall sensor (Push-Pull), +150°C K0 ⁹⁾ = Pulse output Hall sensor (Push-Pull), high resolution (x2) G0 ²⁾ = Pulse output Hall sensor (Push-Pull), high resolution (x4) D0 = 2 phased outputs Hall sensor (Push-Pull) L0 = F/I transmitter, output: 4-20 mA "loop powered" analogue output Z1 = LCD dual totaliser, with battery supply outputs deactivated (ZOK-Z1) Z2 = LCD dosing unit (ZOK-Z2) Z3 = LCD totaliser, rate, outputs: 4-20 mA, alarm, pulse (ZOK-Z3) (impulses not for battery supply) Z5 = as Z3, but with 2 relays/SPDT relays Z6 = Z1 + B0 Z7 = Z3 + B0 Z8 = Z1 + D0 Z9 = Z3 + D0 ZE = LCD counter/flow (ZOE with external supply/with battery) ZB ¹¹⁾ = LCD counter/flow (ZOE without external supply/with battery) HE = H0 + ATEX (Exd) BE ³⁾ = B0 + ATEX (Exd) KE ⁹⁾ = K0 + ATEX (Exd) GE ²⁾ = G0 + ATEX (Exd) DE = D0 + ATEX (Exd) LE = L0 + ATEX (Exd) HA = H0 + ATEX (Exi) BA ³⁾ = B0 + ATEX (Exi) KA ⁹⁾ = K0 + ATEX (Exi) GA ²⁾ = G0 + ATEX (Exi) DA = D0 + ATEX (Exi) 1A = ZOK-E1 + HA (ATEX Exi) 2A = ZOK-E2 + HA (ATEX Exi) 3A = ZOK-E3 + HA (ATEX Exi) 5A = ZOK-E5 + HA (ATEX Exi)	M = M20 N = 1/2" NPT S ⁷⁾ = M20 with cooling fin T ⁷⁾ = 1/2" NPT with cooling fin	0 = without N = without battery Y = special option (specify in clear text, not for ATEX, e. g. check valve)
0.5 - 36 l/h	DON-105H	DON-205H	DON-805H	R1 = G 1/8 N1 = 1/8" NPT				
2 - 100 l/h	DON-110H	DON-210H	DON-810H	R2 = G 1/4 N2 = 1/4" NPT				
15 - 550 l/h	DON-115H	DON-215H	DON-815H	R3 = G 3/8 N3 = 3/8" NPT				
1 - 40	DON-120H	DON-220H	DON-820H	R4 = G 1/2 N4 = 1/2" NPT H4 ⁵⁾ = G 1/2 (100 bar) P4 ⁵⁾ = 1/2" NPT (100 bar)				
10 - 150	DON-125H	DON-225H	DON-825H	R6 = G 1 N6 = 1" NPT F6 = DIN flange, PN 16/40 (DN 25) A6 = ANSI flange, 150 lbs (1") B6 = ANSI flange, 300 lbs (1") H6 ⁵⁾ = G 1 (100 bar) P6 ⁵⁾ = 1" NPT (100 bar)				
15 - 250	DON-130H	DON-230H	DON-830H	R8 = G 1 1/2 N8 = 1 1/2" NPT F8 = DIN flange, PN 16/40 (DN 40) A8 = ANSI flange, 150 lbs (1 1/2") B8 = ANSI flange, 300 lbs (1 1/2")				
30 - 450	DON-135H	DON-235H	DON-835H	R9 = G 2 N9 = 2" NPT F9 = DIN flange, PN 16 (DN 50) C9 ⁹⁾ = DIN flange, PN 40 (DN 50) A9 = ANSI flange, 150 lbs (2") B9 ¹⁾ = ANSI flange, 300 lbs (2")				
50 - 580	DON-140H	DON-240H	DON-840H					
35 - 750	DON-145H	DON-245H	DON-845H	RB = G 3 NB = 3" NPT FB = DIN flange, PN 16 (DN 80) AB = ANSI flange, 150 lbs (3")				
50 - 1000	DON-150H	DON-250H	DON-850H					
75 - 1500	DON-155H	DON-255H	DON-855H	RC = G 4 NC = 4" NPT FC = DIN flange, PN 16 (DN 100) AC = ANSI flange, 150 lbs (4")				
150 - 2500 ¹⁰⁾	DON-160H	DON-260H	DON-860H		M4 ⁶⁾ = mech. totaliser	0 = without		

¹⁾ Only for DON-x35 ²⁾ Only for DON-x04, -x05, -x10 ³⁾ Not for DON-X04, -x05, -x10 ⁴⁾ Replace 'H' with 'G' to order GPH (GPM) ⁵⁾ With steel screws, only for DON-2... and DON-8...
⁶⁾ Only for DON-x20...DON-x60. Please specify the flow direction in clear text while ordering (possible flow directions «bottom to top» or «left to right» or «right to left» only). Standard flow direction is from bottom to top ⁷⁾ Not for electronic options -Zx/-xA, not for DON-1... and DON-8... ⁸⁾ Only for DON-2... ⁹⁾ Only for DON-x04, -x05, -x10, -x15, without Reed switch
¹⁰⁾ Calibrated up to 2200 l/min. Higher flow rate calibration on request ¹¹⁾ Without backlighting ¹²⁾ From DON-x20 PPS ¹³⁾ Only for DON-x04...x20, this version is not calibrated with oil (no calibration certificate). Use K-factor values from the data sheet. ¹⁴⁾ Only for DON-x04...x40



Order Details (cont'd) (Example: DON-320H R4 1 L0 M 0)

Measuring range	Housing material ⁴⁾			Connection	O-Ring Material	Electronics	Cable entry	Option
	Aluminium with PPS/PEEK ¹²⁾ rotor for high viscosities	Stainless steel with rotor for high viscosities	St. steel with PPS/PEEK ¹²⁾ rotor for high viscosities					
0.5-36 l/h	-	-	-	R1 = G 1/8 N1 = 1/8"NPT	1 = FKM 3 ¹⁴⁾ = FEP-O-ring 4 = NBR 5 ¹³⁾ = Fluoro-prene [®] 9 = special materials (not for ATEX)	H0 = Pulse output Hall sensor (Push/Pull)/Reed switch HU ¹⁴⁾ = Pulse output Hall sensor (NPN)/Reed switch, supply 5-30 V _{DC} B0 ⁹⁾ = Pulse output Hall sensor (Push/Pull) for pulsating flow T0 ⁹⁾ = Pulse output Hall sensor (Push-Pull), +150°C K0 ⁹⁾ = Pulse output Hall sensor (Push-Pull), high resolution (x2) G0 ²⁾ = Pulse output Hall sensor (Push-Pull), high resolution (x4) D0 = 2 phased outputs Hall sensor (Push-Pull) L0 = F/I transmitter, output: 4-20 mA "loop powered" analogue output Z1 = LCD dual totaliser, with battery supply outputs deactivated (ZOK-Z1) Z2 = LCD dosing unit (ZOK-Z2) Z3 = LCD totaliser, rate, outputs: 4-20 mA, alarm, pulse (ZOK-Z3) (impulses not for battery supply) Z5 = as Z3, but with 2 relays/SPDT relays Z6 = Z1 + B0 Z7 = Z3 + B0 Z8 = Z1 + D0 Z9 = Z3 + D0 ZE = LCD counter/flow (ZOE with external supply/with battery) ZB ¹¹⁾ = LCD counter/flow (ZOE without external supply/with battery) HE = H0 + ATEX (Exd) BE ⁹⁾ = B0 + ATEX (Exd) KE ⁹⁾ = K0 + ATEX (Exd) GE ²⁾ = G0 + ATEX (Exd) DE = D0 + ATEX (Exd) LE = L0 + ATEX (Exd) HA = H0 + ATEX (Exi) BA ⁹⁾ = B0 + ATEX (Exi) KA ⁹⁾ = K0 + ATEX (Exi) GA ²⁾ = G0 + ATEX (Exi) DA = D0 + ATEX (Exi) 1A = ZOK-E1 + HA (ATEX Exi) 2A = ZOK-E2 + HA (ATEX Exi) 3A = ZOK-E3 + HA (ATEX Exi) 5A = ZOK-E5 + HA (ATEX Exi)	M = M20 N = 1/2" NPT S ⁷⁾ = M20 with cooling fin T ⁷⁾ = 1/2" NPT with cooling fin	O = without N = without battery Y = special option (specify in clear text, not for ATEX, e. g. check valve)
0.5-36 l/h	-	-	-	R1 = G 1/8 N1 = 1/8"NPT				
2-100 l/h	-	-	-	R2 = G 1/4 N2 = 1/4"NPT				
15-550 l/h	DON-315H	DON-415H	DON-915H	R3 = G 3/8 N3 = 3/8"NPT				
1-40	DON-320H	DON-420H	DON-920H	R4 = G 1/2 N4 = 1/2"NPT H4 ⁵⁾ = G 1/2 (100 bar) P4 ⁵⁾ = 1/2"NPT (100 bar)				
10-150	DON-325H	DON-425H	DON-925H	R6 = G 1 N6 = 1"NPT F6 = DIN flange, PN 16/40 (DN 25) A6 = ANSI flange, 150 lbs (1") B6 = ANSI flange, 300 lbs (1") H6 ⁵⁾ = G 1 (100 bar) P6 ⁵⁾ = 1"NPT (100 bar)				
15-250	DON-330H	DON-430H	DON-930H	R8 = G 1 1/2 N8 = 1 1/2"NPT F8 = DIN flange, PN 16/40 (DN 40) A8 = ANSI flange, 150 lbs (1 1/2") B8 = ANSI flange, 300 lbs (1 1/2")				
30-450	DON-335H	DON-435H	DON-935H	R9 = G 2 N9 = 2"NPT F9 = DIN flange, PN 16 (DN 50) C9 ⁹⁾ = DIN flange, PN 40 (DN 50)				
50-580	DON-340H	DON-440H	DON-940H	A9 = ANSI flange, 150 lbs (2") B9 ¹⁾ = ANSI flange, 300 lbs (2")				
35-750	DON-345H	DON-445H	DON-945H	RB = G 3 NB = 3"NPT FB = DIN flange, PN 16 (DN 80)				
50-1000	DON-350H	DON-450H	DON-950H	AB = ANSI flange, 150 lbs (3")				
75-1500	DON-355H	DON-455H	DON-955H	RC = G 4 NC = 4"NPT FC = DIN flange, PN 16 (DN 100) AC = ANSI flange, 150 lbs (4")				
150-2500 ¹⁰⁾	DON-360H	DON-460H	DON-960H					

¹⁾ Only for DON-x35 ²⁾ Only for DON-x04, -x05, -x10 ³⁾ Not for DON-X04, -x05, -x10 ⁴⁾ Replace 'H' with 'G' to order GPH (GPM) ⁵⁾ With steel screws, only for DON-2... and DON-8...
⁶⁾ Only for DON-x20...DON-x60. Please specify the flow direction in clear text while ordering (possible flow directions «bottom to top» or «left to right» or «right to left» only). Standard flow direction is from bottom to top ⁷⁾ Not for electronic options -Zx/-xA, not for DON-3... and DON-9... ⁸⁾ Only for DON-2... ⁹⁾ Only for DON-x04, -x05, -x10, -x15, without Reed switch
¹⁰⁾ Calibrated up to 2200 l/min. Higher flow rate calibration on request ¹¹⁾ Without backlighting ¹²⁾ From DON-x20 PPS ¹³⁾ Only for DON-x04...x20, this version is not calibrated with oil (no calibration certificate). Use K-factor values from the data sheet. ¹⁴⁾ Only for DON-x04...x40

Technical Details MFR-DO (version stainless steel)

Design: two-part screwed body
 Connections: female thread G ¼ ... G 3
 DIN ISO 228-1
 Nominal pressure: PN 40
 Temperature range: -20 °C ... +180 °C
 Mesh size: 200 mesh/75 µm for G ¼, G ¾
 100 mesh/150 µm for G ½, G 1, G 1½
 40 mesh/400 µm for G 2, G 3
 Mounting position: cover toward bottom,
 note specified direction of flow

Materials

Body (1): stainless steel 1.4408, EN1503-1
 Plug (2): stainless steel 1.4408, EN1503-1
 Screen (4): stainless steel 316
 Bonnet (9): stainless steel 1.4408, EN1503-1
 Body seal (11): PTFE
 O-ring (31): FPM

MFR-DO

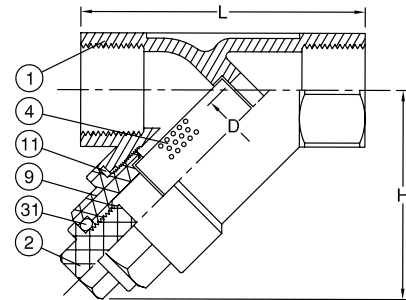

Dimensions, weight and Order Details

MFR-DO stainless steel version

(example: MFR-DOR15)

Order no.	Size		L [mm]	H [mm]	D [mm]	Weight [kg]
	DN	inch				
MFR-DOR08	DN08	¼"	65.0	51.0	10.0	0.25
MFR-DOR10	DN10	⅜"	65.0	51.0	12.0	0.25
MFR-DOR15	DN15	½"	65.0	51.0	15.0	0.25
MFR-DOR25	DN25	1"	90.0	72.0	25.0	0.70
MFR-DOR40	DN40	1½"	120.0	87.0	40.0	1.20
MFR-DOR50	DN50	2"	140.0	103.0	50.0	1.90
MFR-DOR80	DN80	3"	200.0	143.0	80.0	6.16

Dimensions DON-1/-2/-3/-4/-8/-9

DON-x04 DON-x15

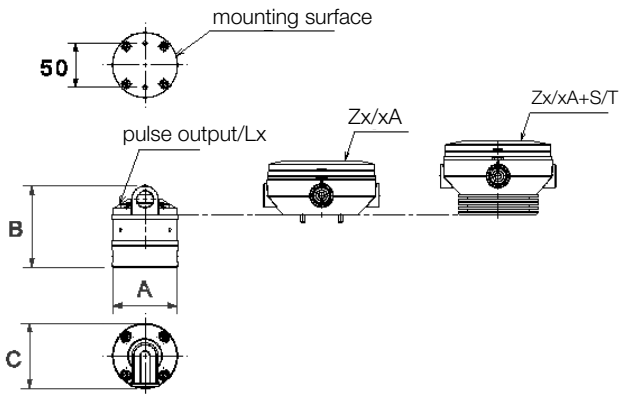

DON-x45 DON-x60

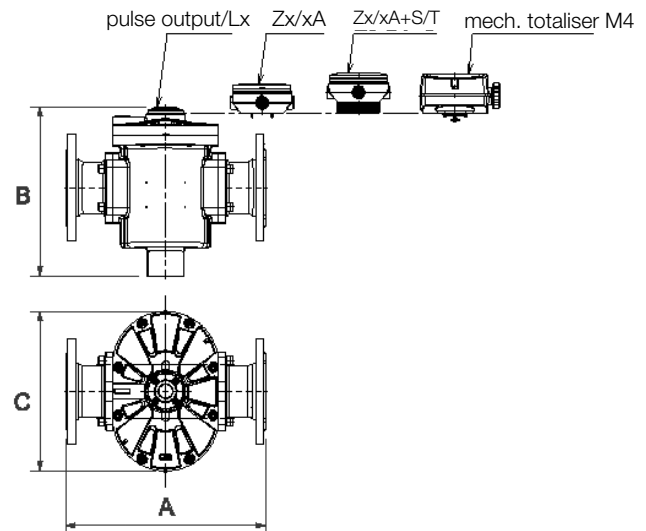

DON-x20 DON-x40

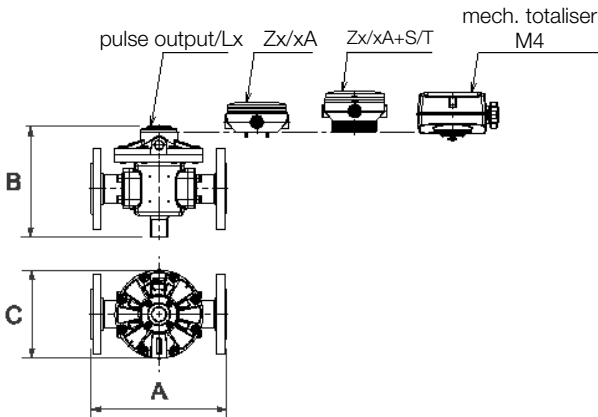

Electronic with LCD display Zx/ xA

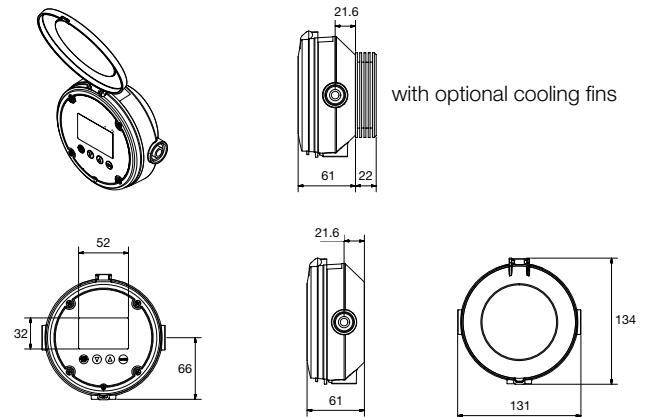

Dimensions DON-1/-2/-3/-4/-8/-9... (± 2 mm)

Model	A [mm]		B [mm]			C [mm]		
	Thread connection	Flange connection	Pulse output/Lx	Zx/Ex	Mechanical totaliser M4	Pulse output/Lx	Zx/Ex	Mechanical totaliser M4
DON-x04	68	-	92	131	-	72	134	-
DON-x05	68	-	92	131	-	72	134	-
DON-x10	68	-	92	131	-	72	134	-
DON-x15	68	-	99	138	-	72	134	-
DON-x20	110	-	105 (101)	134 (130)	182 (178)	112	134	165
DON-x25	176	237	136	165	194	120	134	170
DON-x30	188	252	166	195	223	163	163	200
DON-x35	212	277	172	201	244	180	180	200
DON-x40	212	277	246	275	299	180	180	200
DON-x45	266	354	232	261	284	238	238	239
DON-x50	294	382	229	258	302	290	290	290
DON-x55	294	388	274	303	347	290	290	290
DON-x60	320	414	351	380	424	331	331	331

Note: Dimensions for DON-2/-4/-8/-9... are specified in () only when they are different from DON-1/-3...