

Operating Instructions for Paddle Bellows Flow Monitor

Model: DWU / DWN

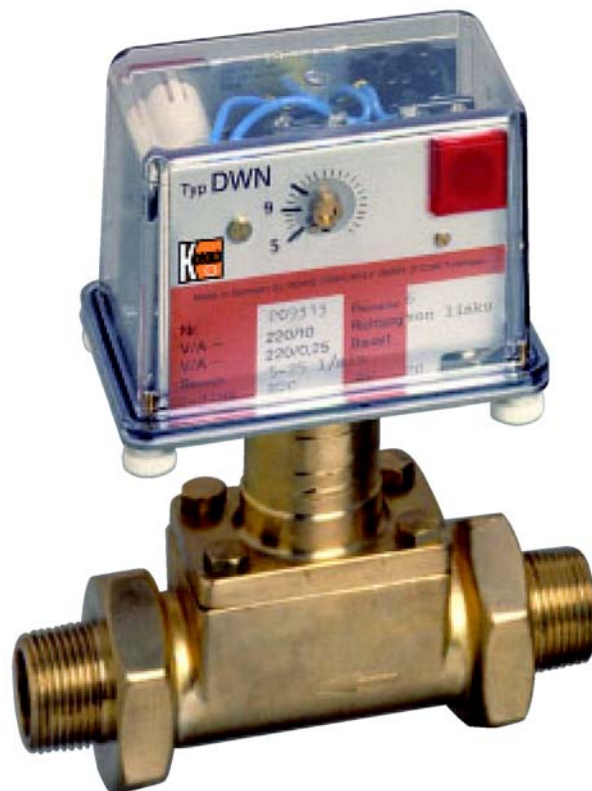

1. Contents

1. Contents.....	2
2. Note	3
3. Instrument Inspection.....	3
4. Regulated Use	4
5. Operating Principle.....	5
6. Mechanical Connection.....	6
6.1 Before installation	6
6.2 Mounting methods	7
7. Electrical Connection	8
8. Limit Switches	8
9. Maintenance	9
10. Recommended Spare Parts.....	9
11. Technical Information.....	10
11.1 Calibration dates.....	10
12. Order Codes	11
13. Dimensions	13
14. Disposal	14
15. EC Declaration of Conformance	15

Manufactured and sold by:

Kobold Messring GmbH
Nordring 22-24
D-65719 Hofheim
Tel.: +49(0)6192-2990
Fax: +49(0)6192-23398
E-Mail: info.de@kobold.com
Internet: www.kobold.com

2. Note

Please read these operating instructions carefully before commissioning the unit for operation, and follow the instructions precisely as described.

The instruction manuals on our website www.kobold.com are always for currently manufactured version of our products. Due to technical changes, the instruction manuals available online may not always correspond to the product version you have purchased. If you need an instruction manual that corresponds to the purchased product version, you can request it from us free of charge by email (info.de@kobold.com) in PDF format, specifying the relevant invoice number and serial number. If you wish, the operating instructions can also be sent to you by post in paper form against an applicable postage fee.

The devices are only to be operated, maintained and serviced by persons familiar with these operating instructions and with currently recommended safety regulations.

When used in machines, the measuring unit should only be placed in operation if the machine in use complies with the EC-machinery guide lines.

PED 2014/68/EU for DWU/DWN-1 and DWU/DWN-2

In acc. with Article 4 Paragraph (3), "Sound Engineering Practice", of the PED 2014/68/EU no CE mark.

3. Instrument Inspection

Instruments are inspected before shipping and sent out in perfect condition.

Should damage to a device be visible, we recommend a thorough inspection of the delivery packaging. In case of damage, please inform your parcel service / forwarding agent immediately, since they are responsible for damages during transit.

The devices are delivered ready for production and have to be protected against external damages. The movement is not locked.

Scope of delivery:

The standard delivery includes:

- Paddle Bellows Flow Monitor for Liquids model: DWU/DWN

4. Regulated Use

Model DWU and DWN instruments are used for monitoring and measuring liquid flows. Only those liquids, that are compatible with the materials of construction, may be measured or monitored. Large measuring errors will result if used with high viscosity media. The instruments are quite insensitive to dirt.

The instruments are available as follows:

- model DWU: Includes indicator for displaying the actual flow, adjustable micro switch to monitor the flow.
- model DWN: Adjustable micro-switch to monitor the flow (no indicator).

Material combinations

Material-Combination	DWU-...5 DWN-...5	DWU-...6 DWN-...6	DWU-...7 DWN-...7
device part			
T-piece	brass	stainless steel	PVC
connecting thread	brass	stainless steel	PVC
connecting flange	steel zinc-plated	stainless steel	PVC
weld-on flange	steel painted	stainless steel	boring pipe box PVC
paddle system	brass	stainless steel	stainless steel
bellows	stainless steel	stainless steel	stainless steel
seals	FPM	FPM	FPM
housing meas. section	stainless steel	stainless steel	stainless steel
covering hood	polycarbonate	polycarbonate	polycarbonate
tmax*	100 °C	100 °C	20 °C (60 °C)
pmax*	16 bar	16 bar	16 bar (2 bar)

*higher on request

5. Operating Principle

The flow meter/monitor works on the principle of dynamic pressure. The flow medium pushes against a pressure plate (1), which causes the system to swing against a tensioned spring (2).

A metal bellows (3) seals the indicator and switch assembly from the flowing liquid.

The connection between the pressure plate (1) and the electrical micro switch (6) is made by a lever arm, which provides a positive link.

The micro switch (6) opens or closes an electrical circuit whenever the pre-selected low or high flow switching points are passed. Thus the change in flow is clearly signalled locally by the switching point pilot lamp (illuminates below set-point); while, at the same time the switch contacts change state (SPDT). The DWU also displays the rate of flow by a pointer (4) on an indicating scale (5).

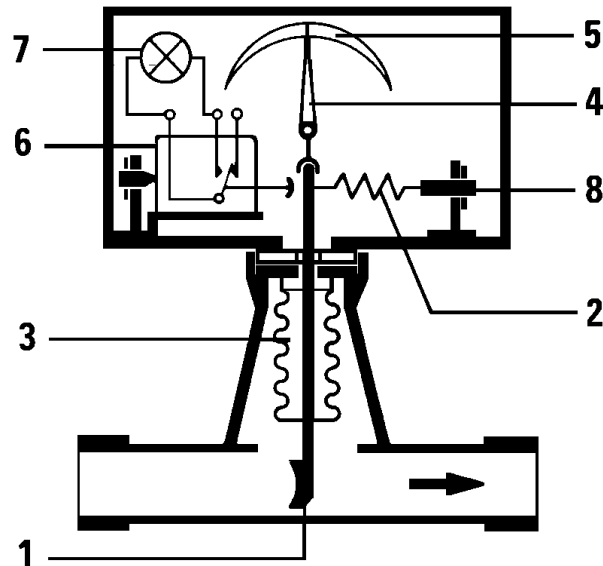

6. Mechanical Connection

6.1 Before installation

- Make sure that the actual flow matches the switching range of the device (please see name plate).
- Be sure that the operating pressure corresponds to the reference pressure specified when placing order.
- Make sure that the maximum allowable operating temperature of the instruments is not exceeded.
- Remove all transport packaging and ascertain that no packing material is left in the instrument.
- The instrument must be oriented in agreement with the positioning symbol on the name plate. This positioning is with reference to the pipe run. Installation in a position different from that given on the identification tag will result in measuring errors.
- The corresponding flow direction is shown on the instrument. If flow is in the opposite direction, the instrument does cease to function.

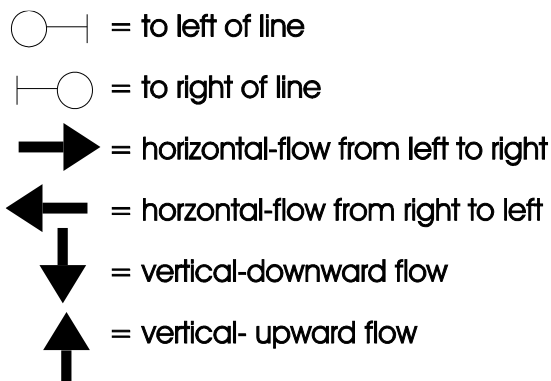

Mounting position

To avoid damages at the measuring system it is especially important to have the biggest possible distance from magnet valves and ball valves. If it is not possible to have a big distance, the valves have to be installed **after** the instruments. To avoid pressure shocks it is very important to open the valves slowly.

Straight runs

When mounting the device, the following inlet and outlet straight run requirements must be met:

- Straight pipe run upstream of instrument :
a distance equal to 10 x pipe diameter
- Straight pipe run downstream of instrument :
a distance equal to 5 x pipe diameter
(d= bore diameter of pipe)

6.2 Mounting methods

The instruments can be supplied with the following connection designs:

Threaded pipe connection (DWU-1, DWN-1)

The pipe is connected directly to the flow monitor. Use only PTFE sealing tape to seal the screw fitting. (do not use hemp).

Flange mounting (DWU-2, DWN-2)

With flange mounting a flat gasket should be used between the instrument and the customer's flange. The gasket is to be supplied by the customer.

Weld-on flange (DWU-3, DWN-3)

The complete flange with screws and sealing is delivered with the instrument. The distance 60mm has to be kept exactly, because this directly affects the calibration of the instrument. The pipe bore must be free from burrs, and all traces of welding material must be removed. The screw whole have to be staggered 90° to the pipe axis. Use the enclosed sealing.

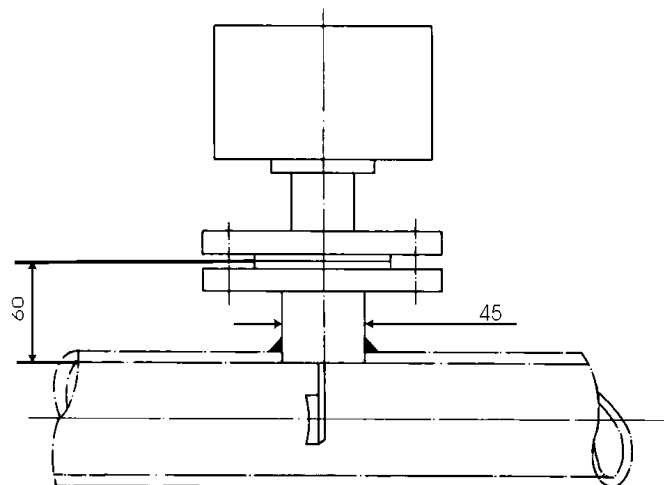

Attention! When mounting the device pay attention to the indicated flow direction. All pipes have to be free from pollution.

If possible, check that the pipe connection thread is fully sealed immediately after mechanical installation.

7. Electrical Connection

Before proceeding, be sure that the electrical supply lines are de-energized.

Standard contact

- Removing the enclosure to gain access to the four polar connector block.
- Additionally to the micro-switch a control lamp is installed. This lamp is for optical control of switch status of the micro-switch.
- The current which is necessary for the lamp is indicated at the label. The max. switching performance is up to 230 V_{AC} / 10 A.
- Please connect the device to ground with help of the screw near cable entry.

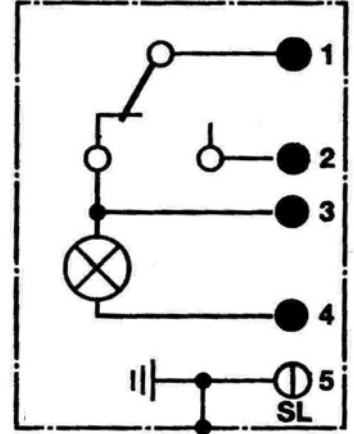

8. Limit Switches

The instruments are delivered with a SPDT micro-switch.

Adjustment of switch points

- model DWU: The adjustment of the switch point is made with the small scale on back of the instrument. The actual flow is indicated at the front side of the unit.
- model DWN: The adjustment of the switch points is made with the small scale on the faceplate of the unit.

9. Maintenance

Flow indicators and -monitors are virtually maintenance-free.

In case of malfunction, check the pipe system for calcification or other obstruction. To do this, all instruments have to be removed completely from the pipe system; except type DWU, (up to a T-piece diameter of 1") which can be separated from the pipe by removing the four screws on the special flange, and turning the instrument by 90 ° to remove it.



Caution! For cleaning do not use sharp-edged steel tools. Damaged instruments can only be repaired in our factory, because they have to be re-calibrated.

Loosening lacquer-protected screws will invalidate the guarantee.

10. Recommended Spare Parts

No spare parts are needed.

To reorder new units, only the serial no on the instrument is to be given.

11. Technical Information

Flow ratio:	threaded connection: max. 1 : 5 mounting flange: max. 1 : 4
Repeat accuracy:	up to 20 l/min.: $\pm 5\%$ 21- 200 l/min.: $\pm 4\%$ 201 and more l/min.: $\pm 3\%$ (based on calibration position and medium at 20 °C)
Pressure loss:	0.1 - 0.3 bar (average pressure loss, value upon request)
Switching hysteresis:	up to 2 bar 10 % > 2 bar depending on pressure
Ambient temperature:	max. 70 °C
Electrical switching:	250 V / 10 A (Standard)
Pilot lamp:	230 V _{AC} , 110 V _{AC} or 24 V _{DC}
Protection type:	IP 55 (IP 65 upon request)

11.1 Calibration dates

Calibration dates, type of device and serial number are indicated at the label. Changes of medium, pressure and position of mounting will influence accuracy.

12. Order Codes

Flow monitor model DWU-1... with male thread connection

Flow range (L/min)		Material combination (bellows/T-piece)			Connection male thread	Pilot lamp	Direction of flow	Location of indicator	Option
min. water	max. water	st. steel/brass	st. steel/st. steel	st. steel/PVC					
1	25	DWU-15..	DWU-16..	DWU-17..	R10= G 3/8 N10= 3/8 NPT	0=230 V _{AC} 1=110 V _{AC} 3=24 V _{DC} X= without pilot lamp	R= from right to left L= from left to right	T= above lead	0= without D= with damping 2= twin contact
1	55	DWU-15..	DWU-16..	DWU-17..	R15= G 1/2 N15= 1/2 NPT		T= from top to bottom B= from bottom to top	R= right of lead L= left of lead	
5	100	DWU-15..	DWU-16..	DWU-17..	R20= G 3/4 N20= 3/4 NPT				
6	150	DWU-15..	DWU-16..	DWU-17..	R25= G 1 N25= 1 NPT				
10	250	DWU-15..	DWU-16..	DWU-17..	R32= G 1 1/4 N32= 1 1/4 NPT				
20	400	DWU-15..	DWU-16..	DWU-17..	R40= G 1 1/2 N40= 1 1/2 NPT				
50	600	DWU-15..	DWU-16..	DWU-17..	R50= G 2 N50= 2 NPT				

Flow monitor model DWU-2... with flange connection

Flow range (L/min)		Material combination (bellows/T-piece)			Connection flange	Pilot lamp	Direction of flow	Location of indicator	Option
min. water	max. water	st. steel/brass	st. steel/st. steel	st. steel/PVC					
1	25	DWU-25..	DWU-26..	-	F10= DN 10 A10= 3/8" ANSI	0=230 V _{AC} 1=110 V _{AC} 3=24 V _{DC} X= without pilot lamp	R= from right to left L= from left to right	T= above lead	0= without D= with damping 2= twin contact
1	55	DWU-25..	DWU-26..	-	F15= DN 15 A15= 1/2" ANSI		T= from top to bottom B= from bottom to top	R= right of lead L= left of lead	
5	100	DWU-25..	DWU-26..	-	F20= DN 20 A20= 3/4" ANSI				
6	150	DWU-25..	DWU-26..	DWU-27..	F25= DN 25 A25= 1" ANSI				
10	250	DWU-25..	DWU-26..	DWU-27..	F32= DN 32 A32= 1 1/4" ANSI				
20	400	DWU-25..	DWU-26..	DWU-27..	F40= DN 40 A40= 1 1/2" ANSI				
50	600	DWU-25..	DWU-26..	DWU-27..	F50= DN 50 A50= 2" ANSI				

Flow monitor model DWU-35.../DWU-36... with weld-on flange / DWU-37... with boring pipe box

Flow range (m ³ /h)		Material combination (bellows/T-piece)			For pipe-cross-section	Pilot lamp	Direction of flow	Location of indicator	Option
min. water	max. water	st. steel/steel	st. steel/st. steel	st. steel/PVC					
1,2	24	DWU-35...	DWU-36...	DWU-37...	W40= DN 40	0=230 V _{AC} 1=110 V _{AC} 3=24 V _{DC} X= without pilot lamp	R= from right to left L= from left to right	T= above lead	0= without D= with damping 2= twin contact
3,0	36	DWU-35...	DWU-36...	DWU-37...	W50= DN 50		T= from top to bottom B= from bottom to top	R= right of lead L= left of lead	
4,8	60	DWU-35...	DWU-36...	DWU-37...	W65= DN 65				
7,2	90	DWU-35...	DWU-36...	DWU-37...	W80= DN 80				
12	144	DWU-35...	DWU-36...	DWU-37...	W1H= DN 100				
18	225	DWU-35...	DWU-36...	DWU-37...	W1Z= DN 125				
24	330	DWU-35...	DWU-36...	DWU-37...	W1F= DN 150				
42	600	DWU-35...	DWU-36...	DWU-37...	W2H= DN 200				
72	900	DWU-35...	DWU-36...	-	W2F= DN 250				
102	1200	DWU-35...	DWU-36...	-	W3H= DN 300				
150	1800	DWU-35...	DWU-36...	-	W3F= DN 350				
180	2400	DWU-35...	DWU-36...	-	W4H= DN 400				
300	3600	DWU-35...	DWU-36...	-	W5H= DN 500				

Flow monitor model DWN-1... with male thread connection

Flow range (L/min)		Material combination (bellows / T-piece)			Connection male thread	Pilot lamp	Direction of flow	Location of indicator	Option
min. water	max. water	st. steel/ brass	st. steel/ st. steel	st. steel/ PVC					
1	25	DWN-15..	DWN-16..	DWN-17..	R10= G 3/8 N10= 3/8 NPT	0=230 V _{AC} 1=110 V _{AC} 3=24 V _{DC} X= without pilot lamp	R= from right to left L= from left to right	T= above lead	0= without D= with damping 2= twin contact
1	55	DWN-15..	DWN-16..	DWN-17..	R15= G 1/2 N15= 1/2 NPT		T= from top to bottom B= from bottom to top	R= right of lead L= left of lead	
5	100	DWN-15..	DWN-16..	DWN-17..	R20= G 3/4 N20= 3/4 NPT				
6	150	DWN-15..	DWN-16..	DWN-17..	R25= G 1 N25= 1 NPT				
10	250	DWN-15..	DWN-16..	DWN-17..	R32= G 1 1/4 N32= 1 1/4 NPT				
20	400	DWN-15..	DWN-16..	DWN-17..	R40= G 1 1/2 N40= 1 1/2 NPT				
50	600	DWN-15..	DWN-16..	DWN-17..	R50= G 2 N50= 2 NPT				

Flow monitor model DWN-2... with flange connection

Flow range (L/min)		Material combination (bellows / T-piece)			Connection flange	Pilot lamp	Direction of flow	Location of indicator	Option
min. water	max. water	st. steel/ brass	st. steel/ st. steel	st. steel/ PVC					
1	25	DWN-25..	DWN-26..	-	F10= DN 10 A10= 3/8" ANSI	0=230 V _{AC} 1=110 V _{AC} 3=24 V _{DC} X= without pilot lamp	R= from right to left L= from left to right	T= above lead	0= without D= with damping 2= twin contact
1	55	DWN-25..	DWN-26..	-	F15= DN 15 A15= 1/2" ANSI		T= from top to bottom B= from bottom to top	R= right of lead L= left of lead	
5	100	DWN-25..	DWN-26..	-	F20= DN 20 A20= 3/4" ANSI				
6	150	DWN-25..	DWN-26..	DWU-27..	F25= DN 25 A25= 1" ANSI				
10	250	DWN-25..	DWN-26..	DWU-27..	F32= DN 32 A32= 1 1/4" ANSI				
20	400	DWN-25..	DWN-26..	DWU-27..	F40= DN 40 A40= 1 1/2" ANSI				
50	600	DWN-25..	DWN-26..	DWU-27..	F50= DN 50 A50= 2" ANSI				

Flow monitor model DWN-35../DWN-36.. with weld-on flange / DWN-37.. with boring pipe box

Flow range (m ³ /h)		Material combination (bellows/connection piece)			For pipe cross-section	Pilot lamp	Direction of flow	Location of indicator	Option
min. water	max. water	st. steel/ steel	st. steel/ st. steel	st. steel/ PVC					
1,2	24	DWN-35...	DWN-36...	DWN-37...	W40= DN 40	0=230 V _{AC} 1=110 V _{AC} 3=24 V _{DC} X= without pilot lamp	R= from right to left L= from left to right	T= above lead	0= without D= with damping 2= twin contact
3,0	36	DWN-35...	DWN-36...	DWN-37...	W50= DN 50		T= from top to bottom B= from bottom to top	R= right of lead L= left of lead	
4,8	60	DWN-35...	DWN-36...	DWN-37...	W65= DN 65				
7,2	90	DWN-35...	DWN-36...	DWN-37...	W80= DN 80				
12	144	DWN-35...	DWN-36...	DWN-37...	W1H= DN 100				
18	225	DWN-35...	DWN-36...	DWN-37...	W1Z= DN 125				
24	330	DWN-35...	DWN-36...	DWN-37...	W1F= DN 150				
42	600	DWN-35...	DWN-36...	DWN-37...	W2H= DN 200				
72	900	DWN-35...	DWN-36...	-	W2F= DN 250				
102	1200	DWN-35...	DWN-36...	-	W3H= DN 300				
150	1800	DWN-35...	DWN-36...	-	W3F= DN 350				
180	2400	DWN-35...	DWN-36...	-	W4H= DN 400				
300	3600	DWN-35...	DWN-36...	-	W5H= DN 500				

13. Dimensions

with thread connection

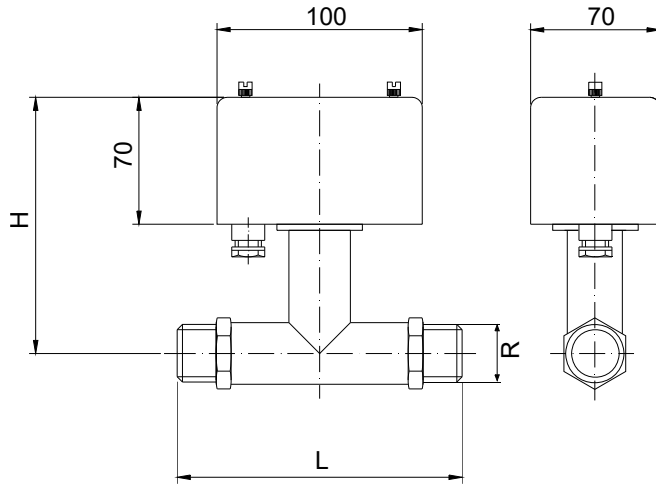

R	H (mm)	L (mm)
3/8	145 + 1	135 + 1
1/2	145 + 1	135 + 1
3/4	145 + 1	135 + 1
1	145 + 1	135 + 1
1 1/4	150 + 2	170 + 2
1 1/2	155 + 2	170 + 2
2	160 + 2	170 + 2

We kindly ask you to provide us with a separate inquiry for the exact dimensions of the material combination 7 (PVC).

with flange connection

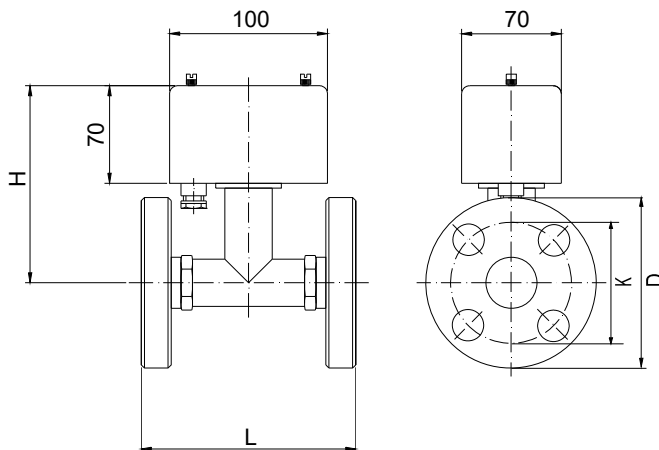

DN	D (mm)	K (mm)	H (mm)	L (mm)
10	90	60	145 + 1	155 + 2
15	95	65	145 + 1	155 + 2
20	105	75	145 + 1	160 + 2
25	115	85	145 + 1	160 + 2
32	140	100	150 + 2	190 + 2
40	150	110	155 + 2	190 + 2
50	165	125	160 + 2	190 + 2

We kindly ask you to provide us with a separate inquiry for the exact dimensions of the material combination 7 (PVC).

with weld-on flange

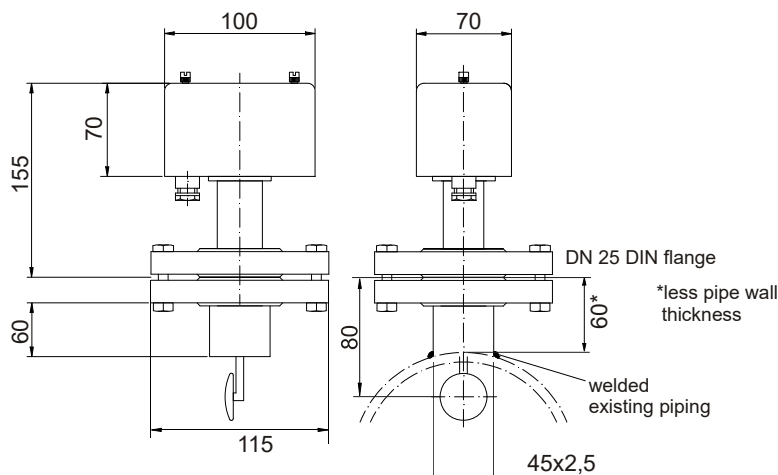

We kindly ask you to provide us with a separate inquiry for the exact dimensions of the material combination 7 (PVC).

14. Disposal

Note!

- Avoid environmental damage caused by media-contaminated parts
- Dispose of the device and packaging in an environmentally friendly manner
- Comply with applicable national and international disposal regulations and environmental regulations.

Batteries

Batteries containing pollutants are marked with a sign consisting of a crossed-out garbage can and the chemical symbol (Cd, Hg, Li or Pb) of the heavy metal that is decisive for the classification as containing pollutants:

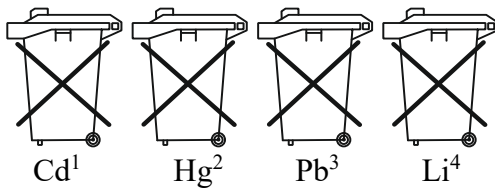

1. „Cd" stands for cadmium
2. „Hg" stands for mercury
3. „Pb" stands for lead
4. „Li" stands for lithium

Electrical and electronic equipment

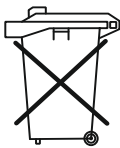

15. EC Declaration of Conformance

We, Kobold-Messring GmbH, Hofheim-Ts., Germany, declare under our sole responsibility that the product:

Paddle Bellows Flow Monitor model DWU / DWN -...

to which this declaration relates is in conformity with the standards noted below:

EN 61010-1:2010 Safety requirements for electrical equipment for measurement, control and laboratory use - Part 1: General requirements

EN 50581:2012 Technical documentation for the assessment of electrical and electronic products with respect to the restriction of hazardous substances

Also the following EC guidelines are fulfilled:

2014/30/EU **EMC Directive**
2011/65/EU **RoHS (category 9)**



H. Peters
General Manager

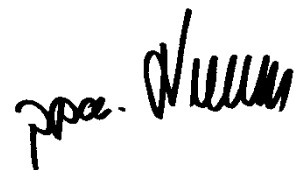

M. Wenzel
Proxy Holder

Hofheim, 27 Febr. 2019