

**INSTALLATION & OPERATION INSTRUCTIONS
FOR KOBOLD KFR-1000 THRU KFR-45000 SERIES FLOWMETERS**

The KFR-1000 through KFR-45000 acrylic block flowmeters are available in various ranges in both SAE and SI units for air and water (see chart on other side). These direct reading meters are also available for other gases and liquids. If the meter will be used with fluids other than air or water, please consult chemical compatibility data for possible effects on the meter. When properly installed and maintained, these durable acrylic meters will provide years of trouble-free operation.

SPECIFICATIONS	
ACCURACY:	KFR-1000/2000 Series <ul style="list-style-type: none"> • ± 5% Full Scale KFR-3000/45000 Series <ul style="list-style-type: none"> • ± 3% Full Scale
FLOATS:	Black Glass, Stainless Steel, Aluminum or Black POM
METER BODY:	Clear Acrylic
FITTINGS:	Brass or Stainless Steel
O-RINGS:	<ul style="list-style-type: none"> • NBR O-rings with Brass Fittings • FKM O-rings with Stainless Steel fittings
VALVES:	Brass or Stainless Steel Cartridge Type (Optional)
MOUNTING INSERTS:	10-32 UNF
MAXIMUM TEMPERATURE:	150 °F (65 °C)
MAX. PRESSURE:	100 PSIG (690 kPa)

UNPACKING

Precautions have been taken to prevent any damage from occurring during shipment. If the meter is received damaged, *report it to your carrier immediately*. Before installing, verify that you have the model and flow range required.

ACHIEVING ACCURATE FLOWRATES

To obtain an accurate flowrate, the float must be read at the position indicated on the meter. If the meter uses a ball float, the flowrate is determined by reading the center of the ball. Additionally, the flowmeter should be installed in a manner, which minimizes both external vibrations and internal flow variations. Special care should be taken so that the connections

to the meter's inlet and outlet fittings do not overly restrict the liquid or gas flow being metered. This could result in a reduced flow volume, preventing the meter from reaching its maximum flowrate. Furthermore, internal pressures could be affected, which can cause inaccurate flow readings. On start-up, slowly purge any fluid trapped in the meter.

INSTALLATION

These meters are supplied with a 5/8" or 7/8" hex nut on the inlet and outlet fittings. When installing 1/8-27 MNPT or 1/8-18 MNPT fittings into the meter, **place the appropriate size wrench on the hex to prevent the inlet/outlet fitting from rotating. Torque only to 60 in-lbs.** Failure to do so will cause the fitting to rotate, and may damage the meter body, causing leaks and/or meter failure. Use pipe thread sealant or PTFE tape to ease installation and provide a better seal. This meter is supplied with #10-32 threaded inserts for mounting. When installing, use slotted screws and torque to a maximum of 35 in-lbs. Mounting dimensions are shown in the figure on the reverse side.

CLEANING AND DISASSEMBLY

Occasional cleaning may be required if dirt appears in the flow tube or if float movement becomes restricted. To clean, remove the top plug and remove the float. Wash the tapered hole and top plug with a mild liquid detergent and soft brush. Rinse all parts with clean water and dry thoroughly with clean air or nitrogen. **Do not use solvents to clean this meter** as they will attack the acrylic and destroy the meter.

REASSEMBLY

Check to make sure that all parts are clean and dry. To lubricate the o-rings, apply a small amount of halocarbon grease prior to reassembly. If applicable, reinstall the rod guide assembly into the flowmeter body. Make sure the rod guide is seated firmly in the body of the meter. Reinstall the top plug, making sure that the rod guide is properly aligned. If you have any questions regarding the installation, maintenance or use of this flowmeter, please call one of our friendly engineers at (412) 788-2830.

CAUTION

THIS FLOWMETER IS DESIGNED FOR USE WITH NON-HAZARDOUS FLUIDS AT PRESSURES UP TO 100 PSI (690 kPa) AND TEMPERATURES UP TO 150 °F (65 °C). DO NOT USE HAZARDOUS FLUIDS AND DO NOT EXCEED TEMPERATURE OR PRESSURE LIMITS. USE WITH HAZARDOUS FLUIDS OR EXCEEDING THE PRESSURE AND TEMPERATURE LIMITS MAY CAUSE FAILURE WHICH COULD RESULT IN INJURY.

DIMENSIONS		KFR-1000/2000	KFR-3000/4000	KFR-35000/45000*
A	IN.	4	6 ½	6 5/8
	mm	102	165	164
B	IN.	3	5 ½	5 1/2
	mm	76.2	140	140
C	IN.	1	1 3/8	1 1/8
	mm	25.1	34.9	28.6
D	IN.	1 5/8	3 ½	3 ½
	mm	41.3	88.9	38.1
E	IN.	1 3/16	1 1/2	1 1/2
	mm	30.2	38.1	38.1
F	IN.	1 1/8	1 1/8	1 3/8
	mm	29.6	28.6	34.9
G	IN.	1/8-27 FNPT	1/8-27 FNPT	1/4-18 FNPT
	mm			

* DOES NOT INCLUDE A 1/8" BACKPLATE!

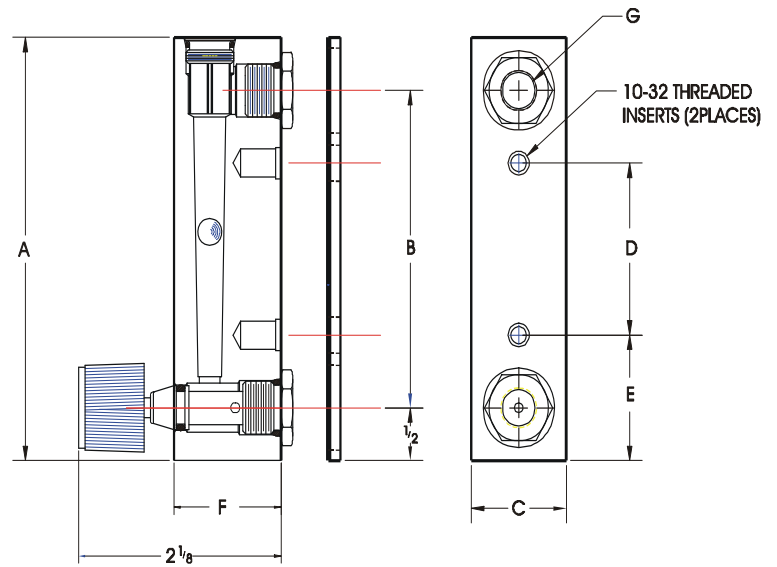

KFR-1000/2000 SERIES FLOW RATES			
RANGE	MODEL	RANGE	MODEL
SCFH OF AIR	KFR-	LPM OF AIR	KFR-
0.1-1	2100, 2200	0.04-0.5	2112, 2212
0.2-2	2101, 2201	0.1-1	2113, 2213
0.4-5	2102, 2202	0.2-2.5	2129, 2229
1-10	2103, 2203	0.4-5	2114, 2214
2-20	2104, 2204	1-10	2115, 2215
3-30	2105, 2205	2-25	2116, 2216
4-50	2106, 2206	4-50	2117, 2217
10-100	2107, 2207	10-100	2118, 2218
20-200	2108, 2208	GPH OF WATER	KFR-
CCM OF WATER	KFR-		
5-50	2109, 2209	0.4-5	1119, 1219
10-100	2110, 2210	1-10	1120, 1220
20-240	2111, 2211	2-20	1121, 1221
		4-40	1122, 1222

KFR-35000/45000 FLOW RATES			
RANGE	MODEL	RANGE	MODEL
SCFM OF AIR	KFR-	LPM OF AIR	KFR-
0.5-5	45167, 45267	14-140	45172, 45272
1-10	45165, 45265	30-280	45170, 45270
** 2-20	45168, 45268	** 60-560	45173, 45273
GPM OF WATER	KFR-	LPM OF WATER	KFR-
0.2-2.5	35164, 35264	0.8-9	35169, 35269
0.4-5	35166, 35266	1.5-20	35171, 35271

** Models Not Available With Valves

KFR-3000/4000 SERIES FLOW RATES			
RANGE	MODEL	RANGE	MODEL
SCFH OF AIR	KFR-	CCM OF WATER	KFR-
0.4-5	4130, 4230	4-50	4138, 4238
1-10	4131, 4231	10-120	4156, 4256
2-20	4132, 4232	25-225	4151, 4251
4-40	4133, 4233	40-400	4150, 4250
10-100	4134, 4234	40-660	4152, 4252
14-150	4135, 4235	100-1500	4153, 4253
20-200	4136, 4236	200-3000	4154, 4254
CCM OF AIR	KFR-	300-3700	4155, 4255
		GPH OF WATER	KFR-
100-1000	4139, 4239	1-10	3145, 3245
LPM OF AIR	KFR-	2-25	3146, 3246
		4-50	3147, 3247
0.4-5	4140, 4240	6-60	3148, 3248
1-10	4141, 4241	SCFM OF AIR	KFR-
2-20	4142, 4242		
3-30	4143, 4243		
4-50	4144, 4244	0.3-3	4137, 4237
10-100	4147, 4247		

NOTE: The KFR-35000/45000 series models are dual scale units (i.e. SCFM/ SCFH, GPM/GPH, LPM/LPH)

CONTINUED PRODUCT IMPROVEMENT MAY RESULT IN SPECIFICATION REVISIONS

WHEN ORDERING PARTS PLEASE INCLUDE PART DESCRIPTION, ITEM NUMBER AND TYPE OF MATERIAL REQUIRED.

**INSTALLATION & OPERATION INSTRUCTIONS
FOR KOBOLD KFR-5000 AND KFR-6000 SERIES FLOWMETERS**

The KFR-5000 and KFR-6000 acrylic block flowmeters are available in various ranges in both SAE and SI units for air and water (see chart on other side). These direct reading meters are also available for other gases and liquids. If the meter will be used with fluids other than air or water, please consult chemical compatibility data for possible effects on the meter. When properly installed and maintained, these durable acrylic meters will provide years of trouble-free operation.

SPECIFICATIONS	
ACCURACY:	± 2% Full Scale
FLOAT:	Stainless Steel
WETTED PARTS:	316 SS, Acrylic, PVC, NBR
PANEL MT. VALVE (OPTION: PMV1)	316 SS
METER BODY:	Clear Acrylic
FITTINGS:	1" FNPT PVC
O-RINGS:	NBR
MOUNTING INSERTS:	10-32 UNF
MAX. TEMPERATURE:	150 °F (65 °C)
MAX. PRESSURE:	100 PSIG (690 kPa)

UNPACKING

Precautions have been taken to prevent any damage from occurring during shipment. Remove the protective pipe cleaner securing the float from the meter through the appropriate inlet / outlet fitting and discard. If the meter is received damaged, *report it to your carrier immediately*. Before installing, verify that you have the model and flow range required.

ACHIEVING ACCURATE FLOWRATES

To obtain an accurate flowrate, the float must be read at the position indicated on the meter. Additionally, the flowmeter should be installed in a manner, which minimizes both external vibrations and internal flow variations. Special care should be taken so that the connections to the meter's inlet and outlet fittings do not overly restrict the liquid or gas flow being metered. This could result in a reduced flow volume, preventing the meter from reaching its maximum flowrate. Furthermore, internal pressures could be affected, which can cause inaccurate flow readings. On start-up, slowly purge any fluid trapped in the meter.

INSTALLATION

These meters are supplied with round 1" FNPT PVC inlet and outlet fittings. When installing the meter, securely hold the meter's fittings from rotating while connecting the flow lines. (Use pipe thread sealant or PTFE tape to achieve a positive seal when connecting the flowmeter.) **Failure to hold the meter fittings or over-tightening may cause damage to the fitting, flowmeter or both; which will result in leaks or meter failure.** The meter is supplied with #10-32 threaded inserts for mounting. When installing, use slotted screws and torque to a maximum of 35 in-lb. Mounting dimensions are shown in the figure on the reverse side.

CLEANING AND DISASSEMBLY

Occasional cleaning may be required if dirt appears in the flow tube or if float movement becomes restricted. To clean, remove the top plug (standard back) or the outlet fitting (inline) and remove the rod guide assembly. Wash the tapered hole; float stops and top plug with a mild liquid detergent and soft brush. Rinse all parts with clean water and dry thoroughly with clean air or nitrogen. **Do not use solvents to clean this meter** as they will attack the acrylic and destroy the meter.

CAUTION

THIS FLOWMETER IS DESIGNED FOR USE WITH NON-HAZARDOUS FLUIDS AT PRESSURES UP TO 100 PSI (690 kPa) AND TEMPERATURES UP TO 150 °F (65 °C). DO NOT USE HAZARDOUS FLUIDS AND DO NOT EXCEED TEMPERATURE OR PRESSURE LIMITS. USE WITH HAZARDOUS FLUIDS OR EXCEEDING THE PRESSURE AND TEMPERATURE LIMITS MAY CAUSE FAILURE WHICH COULD RESULT IN INJURY.

REASSEMBLY

Check to make sure that all parts are clean and dry. To lubricate the o-rings, apply a small amount of halocarbon grease prior to reassembly. Replace the float on the rod guide and reinstall the float stops. Reinstall the rod guide assembly into the flowmeter body. Make sure the rod guide is seated firmly in the body of the meter for a standard back meter or in the inlet fitting of the Inline meter. (For meters with

valves, it will be necessary for the rod guide to pass through the slot in the valve tip.) Reinstall the top plug or the outlet fitting, making sure that the rod guide is properly aligned.

If you have any questions regarding the installation, maintenance or use of this flowmeter, please call one of our friendly engineers at (412) 788-2830.

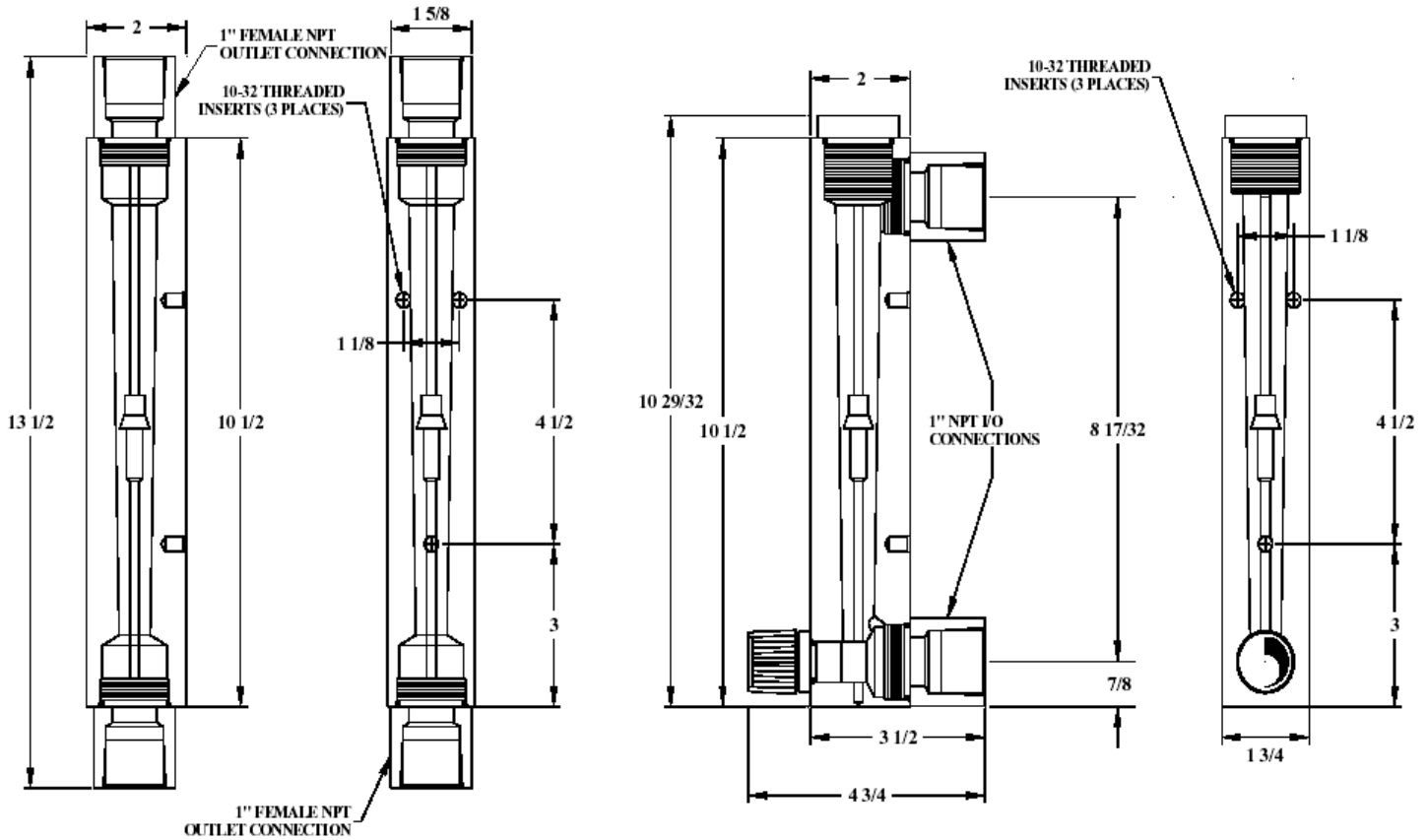

INLINE METER			
SCFM OF AIR		GPM OF WATER	
RANGE	MODEL	RANGE	MODEL
3-25	KFR-6350	0.4-5	KFR-5356
4-50	KFR-6351	1-10	KFR-5357
10-100	KFR-6352	2-20	KFR-5358
LPM AIR		LPM WATER	
RANGE	MODEL	RANGE	MODEL
100-700	KFR-5353	1-19	KFR-5359
100-1400	KFR-5354	4-36	KFR-5360
400-4000	KFR-5355	5-75	KFR-5361

PANEL MOUNT METER (316 SS valve shown above is optional - add suffix "V1")			
SCFM OF AIR		GPM OF WATER	
RANGE	MODEL	RANGE	MODEL
3-25	KFR-6350PM	0.4-5	KFR-5356PM
4-50	KFR-6351PM	1-10	KFR-5357PM
10-100	KFR-6352PM	2-20	KFR-5358PM
LPM AIR		LPM WATER	
RANGE	MODEL	RANGE	MODEL
100-700	KFR-5353PM	1-19	KFR-5359PM
100-1400	KFR-5354PM	4-36	KFR-5360PM
400-3400	KFR-5355PM	5-75	KFR-5361PM

CONTINUED PRODUCT IMPROVEMENT MAY RESULT IN SPECIFICATION REVISIONS

WHEN ORDERING PARTS PLEASE INCLUDE PART DESCRIPTION, ITEM NUMBER AND TYPE OF MATERIAL REQUIRED.

Disposal

Note!

- Avoid environmental damage caused by media-contaminated parts
- Dispose of the device and packaging in an environmentally friendly manner
- Comply with applicable national and international disposal regulations and environmental regulations.

Batteries

Batteries containing pollutants are marked with a sign consisting of a crossed-out garbage can and the chemical symbol (Cd, Hg, Li or Pb) of the heavy metal that is decisive for the classification as containing pollutants:

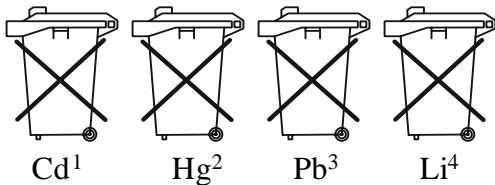

1. „Cd" stands for cadmium
2. Hg" stands for mercury
3. „Pb" stands for lead
4. Li" stands for lithium

Electrical and electronic equipment

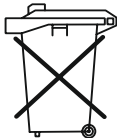

EU Declaration of Conformance

We, KOBOLD Messring GmbH, Hofheim-Ts, Germany, declare under our sole responsibility that the product:

Low Volume Variable Area Flowmeter

Model: KFR

to which this declaration relates is in conformity with the standards noted below:

EN IEC 63000:2018 Technical documentation for the assessment of electrical and electronic products with respect to the restriction of hazardous substances

Also the following EC guidelines are fulfilled:

2011/65/EU
2015/863/EU

RoHS (category 9)
Delegated Directive (RoHS III)



H. Volz
General Manager



M. Wenzel
Proxy Holder

Hofheim, 18 March 2022

UK Declaration of Conformity

We, KOBOLD Messring GmbH, Hofheim-Ts, Germany, declare under our sole responsibility that the product:

Low Volume Variable Area Flowmeter

Model: KFR

to which this declaration relates is in conformity with the standards noted below:

BS EN IEC 63000:2018

Technical documentation for the assessment of electrical and electronic products with respect to the restriction of hazardous substances.

Also, the following UK guidelines are fulfilled:

S.I. 2012/3032

The Restriction of the Use of Certain Hazardous Substances in Electrical and Electronic Equipment Regulations 2012



H. Volz
General Manager



M. Wenzel
Proxy Holder

Hofheim, 18 March 2022

Version K05/0722

Manufactured and sold by:

Kobold Messring GmbH
Nordring 22-24
D-65719 Hofheim
Tel.: +49(0)6192-2990
Fax: +49(0)6192-23398
E-Mail: info.de@kobold.com
Internet: www.kobold.com