

**Operating Instructions  
for  
Plastic Flow Meter**

**Model: KSK**



## 1. Contents

---

1. Contents.....	2
2. Note .....	3
3. Instrument Inspection.....	3
4. Regulation Use .....	4
5. Operating Principle.....	4
6. Mechanical Connection.....	5
7. Electrical Connection .....	6
7.1. Reed Contact, bistable (option) .....	6
7.2. Electronic Contact (option).....	7
8. Operation .....	8
9. Maintenance .....	9
10. Technical Information.....	10
11. Order Codes .....	11
12. Dimensions .....	12
13. Disposal .....	13
14. EU Declaration of Conformance .....	14
15. UK Declaration of Conformity.....	15

### Manufactured and sold by:

Kobold Messring GmbH  
Nordring 22-24  
D-65719 Hofheim  
Tel.: +49(0)6192-2990  
Fax: +49(0)6192-23398  
E-Mail: info.de@kobold.com  
Internet: www.kobold.com

## **2. Note**

---

Please read these operating instructions before unpacking and putting the unit into operation. Follow the instructions precisely as described herein.

The instruction manuals on our website [www.kobold.com](http://www.kobold.com) are always for currently manufactured version of our products. Due to technical changes, the instruction manuals available online may not always correspond to the product version you have purchased. If you need an instruction manual that corresponds to the purchased product version, you can request it from us free of charge by email ([info.de@kobold.com](mailto:info.de@kobold.com)) in PDF format, specifying the relevant invoice number and serial number. If you wish, the operating instructions can also be sent to you by post in paper form against an applicable postage fee.

The devices are only to be used, maintained and serviced by persons familiar with these operating instructions and in accordance with local regulations applying to Health & Safety and prevention of accidents.

When used in machines, the measuring unit should be used only when the machines fulfil the EC-machine guidelines.

**as per PED 2014/68/EU**

In acc. with Article 4 Paragraph (3), "Sound Engineering Practice", of the PED 2014/68/EU no CE mark.

Diagram 6, Pipe, Group 1 dangerous fluids

## **3. Instrument Inspection**

---

Instruments are inspected before shipping and sent out in perfect condition.

Should damage to a device be visible, we recommend a thorough inspection of the delivery packaging. In case of damage, please inform your parcel service / forwarding agent immediately, since they are responsible for damages during transit.

### **Scope of delivery:**

The standard delivery includes:

- Plastic Flow Meter model: KSK

## 4. Regulation Use

---

Any use of the Plastic Flow Meter, model: KSK, which exceeds the manufacturer's specification, may invalidate its warranty. Therefore, any resulting damage is not the responsibility of the manufacturer. The user assumes all risk for such usage.

## 5. Operating Principle

---

Kobold Plastic Flow Meters and Switches, model KSK, are based on the well-known suspended float principle.

They are used for measuring and monitoring flows in closed pipes.

The media flows, from below, through a conical plastic measuring tube. This raises the float and the flow rate can be read off against scale. The instruments can be fitted with bistable switches.

### **Special advantages**

- Shock resistant and corrosion-resistant
- May be inserted/removed radially
- Special scales available
- Short installation length
- Plastic float and fitting generally made of PVDF

## **6. Mechanical Connection**

---

### **Before Installation:**

- Remove all transportation safety locks and ensure that no packing material remains within the unit.
- Be sure that the maximum allowable operating pressure and temperature is not exceeded (see Technical Data).
- Install the flow meter in the piping system, ensure the instrument is under no mechanical stress/tension (install support bracing if necessary).
- Protect the measuring tube from external damage.
- Avoid pressure peaks in the measuring tube, e.g. from sudden surges or stoppage of flow.
- The units with bistable reed switch may not be installed within an inductive field.
- If possible, immediately after making mechanical connections, check whether the connections are properly sealed with no evidence of leakage (see section 8 Operation).



---

**Detailed information regarding installation of float flow meters is available in VDI/VDE guidelines 3513.**

---

## 7. Electrical Connection

---

### 7.1. Reed Contact, bistable (option)

- Make sure that the supply wires are de-energized.
- Loosen the plug-cap holding screw and remove the cap from the switch housing.
- Connect the supply lines inside the plug in accordance with the connection diagram opposite.

**N/O contact**

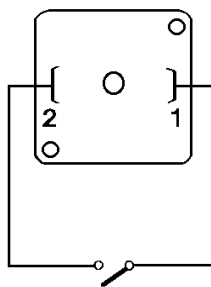

**Changeover contact**

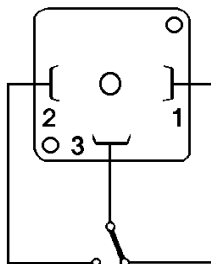

- If the set point has not yet been adjusted, it may be done at this point. (see section 8. Operation).
- Set the plug to the socket and fix it with the safety screws.



**Attention! The stated electrical parameters of the contact may not be exceeded, even for a short period of time. For inductive or capacitive loads, we recommend the use of contact protection measures respectively the application of a contact protection relay.**

## 7.2. Electronic Contact (option)

- Make sure that the supply wires are de-energized.
- Loosen the plug-cap holding screw and remove the cap from the switch housing.
- Connect the supply lines inside the plug-in accordance with the connection diagram opposite.

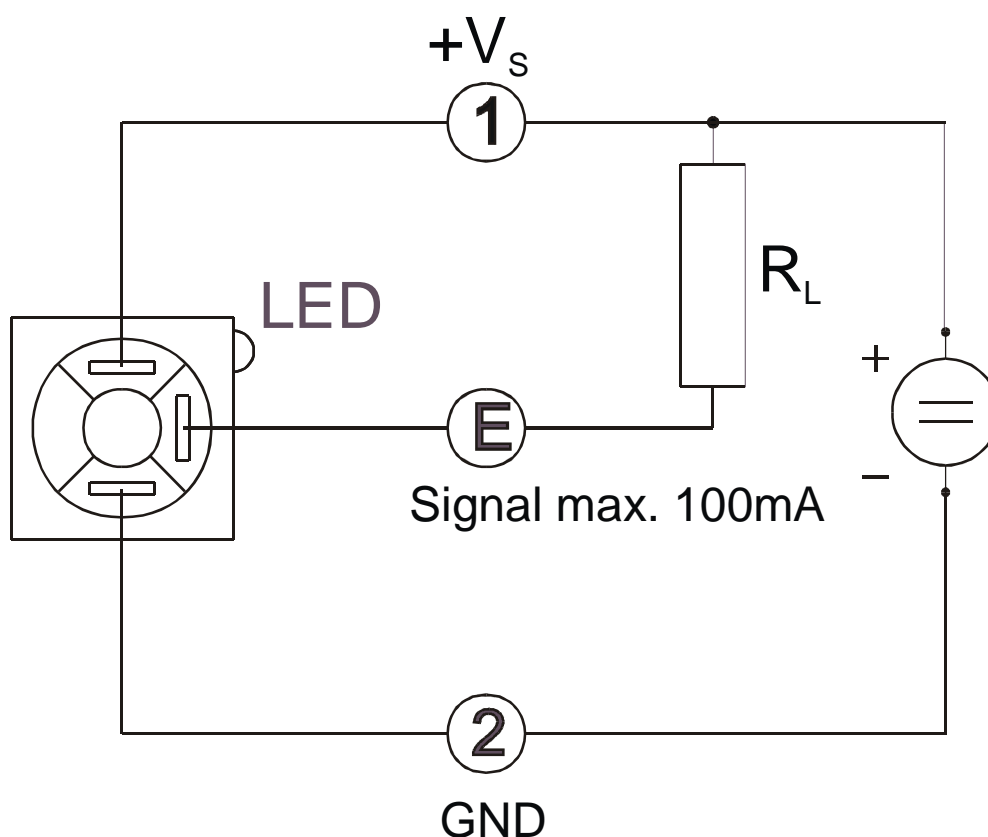

- If the set point has not yet been adjusted, it may be done at this point. (see section 8. Operation).
- Set the plug to the socket and fix it with the safety screws.



**Attention! The stated electrical parameters of the contact may not be exceeded. For inductive or capacitive loads, we recommend the use of contact protection measures respectively the application of a contact protection relay.**

After connecting the external devices, and adjusting the switch housing to the desired switch points, all the connection work is completed. The unit is ready for operation.

## 8. Operation

---



**In order to initialise the bistable switching function, it is essential that the float activates the contact once in each direction.**

---

### **Adjustment of limit-values**

The switch-point can be adjusted to the desired levels by using both red sliders as reference points.

*Reference edge for falling flow:* bottom-edge, switch housing

*Reference edge for rising flow:* approx. 5 mm above the bottom-edge of switch housing.

Slide the switch housing up or down until the reference edge coincides with the desired switch-point scale reading.

### **Hysteresis**

Hysteresis is the difference between the level at which “switch-on” occurs during rising flow and the level at which “switch-off” occurs during decreasing flow. The hysteresis is approximately 5 mm on the float range.

### **Overranging**

With non-pulsating flow, the maximum flow rate can be exceeded. Only an increase in pressure loss will result (max. permissible operating pressure must not be exceeded!)

## **9. Maintenance**

---

If the medium to be measured is clean, the series KSK is virtually maintenance-free. If deposits form on the inner housing or parts, periodic cleaning of the unit is recommended. Remove the units from the piping with a suitable tool; clean the flow meter with a suitable cleaning agent or make use of an ultrasonic bath.

## 10. Technical Information

---

### Materials

Measuring tube:	Trogamide T (KSK 1..) or polysulfone (KSK 2..) not transparent, but <b>opaque</b> translucent
Float:	PVDF
O-rings:	EPDM (KSK-1../KSK-2..)
Max. operating pressure:	PN 10
Max. operating temp.:	<b>KSK 1...</b> max. 60 °C (0...60 °C) <b>KSK 2...</b> max. 100 °C (0...100 °C) (60 °C with PVC screwed fitting) max. 85 °C (with contact)
Accuracy class:	4 (according to VDE / VDI 3513, sheet 2)

### Connection (standard)

KSK 1.. and KSK 2..:	PVC glue-in connection
KSK 3...:	Welding sleeve

### Connection (optional) for KSK 1... and KSK 2... only

KSK- ..080../..150../..200..:	Brass or stainless steel union nut with G 1/2 female or male or G 3/4 male
KSK- ..300../..500../..999..:	PVC union nut with G 1/2; G 3/4, G 1 internal thread or G1 female cast iron
KSK- ..015../..025../..050....100..:	PVC G 1/4 female

### Contacts (optional)

The flow meter can be fitted with either reed contacts or electronic contacts.

#### *Reed contacts (bistable)*

Switching voltage*:	max. 130 V <sub>AC</sub>
Breaking capacity*:	max. 10 W / 10 VA
Switching current*:	max. 0.5 A
Contact resistance:	< 150 m Ohm
Insulation resistance:	> 10 <sup>5</sup> Ohm
Allowed ambient temperature:	0...+ 55 °C
Protection:	IP 65
Contact hysteresis:	approximately 5 - 7 mm floater distance

\* Short-time overshoot is not allowed. The use of a contact protection relay is therefore recommended (see Accessories Z2 brochure).

## Electronic contacts (bistable)

The contact operates electronically with no mechanical parts that are subject to wear and tear.

Operating voltage:	9 - 24 V <sub>DC</sub>
Switching output:	NPN max. 100 mA
Ambient temperature:	0...+ 55°C
Protection:	IP 65
Contact hysteresis:	< 6 mm
Dimensions:	33 x 18 x 40 mm
Weight with plug:	16 g
Output signal (with LED at the top)	
Float above contact across PIN 1 and PIN E:	0 V
Float below contact across PIN 1 and PIN E:	9 - 24 V LED out

## 11. Order Codes

Example: **KSK-1015H K16 00**

Measuring range water L/h	Order no. Trogamide	Order no. Polysulfone	Scale measuring range see table	Thread fitting option	Contact option		
1.5 - 11	KSK - 1015...	KSK - 2015...	<b>Standard</b> H = L/h Water	<b>K16</b> = PVC-glue-in connection Ø 16 <b>V16</b> = PVDF-Welding sleeve Ø 16* <b>P08</b> = PVC G 1/4 female	<b>00</b> = without contact <b>S0</b> = 1 N/O contact <b>SS</b> = 2 N/O contacts <b>SC</b> = 1 N/O contact/ 1 NC contact <b>C0</b> = 1 NC contact <b>CC</b> = 2 NC contacts <b>E0</b> = 1 electr. cont. <b>EE</b> = 2 electr. cont.		
2.5-25	-	-					
2.5 - 30	KSK - 1025...	KSK - 2025...					
5 - 50	KSK - 1050...	KSK - 2050...					
10 - 100	KSK - 1100...	KSK - 2100...					
8 - 80	KSK - 1080...	KSK - 2080...	<b>Special scale</b> <b>A</b> = air; 0 bar gauge <b>B</b> = air; 1 bar gauge <b>C</b> = air; 2 bar gauge <b>D</b> = air; 3 bar gauge <b>E</b> = air; 4 bar gauge <b>F</b> = air; 5 bar gauge <b>G</b> = air; 6 bar gauge <b>I</b> = air; 7 bar gauge <b>K</b> = air; 8 bar gauge <b>L</b> = air; 9 bar gauge <b>M</b> = air; 10 bar gauge <b>Y</b> = other	<b>K20</b> = PVC-glue-in connection Ø 20 <b>V20</b> = PVDF-Welding sleeve Ø 20* <b>IG1</b> = brass G 1/2 female <b>AG1</b> = brass G 1/2 male <b>AG3</b> = brass G 3/4 male <b>IG2</b> = stainless steel G 1/2 female <b>AG2</b> = stainless steel G 1/2 male <b>AG4</b> = stainless steel G 3/4 male	<b>00</b> = without contact <b>S0</b> = 1 N/O contact <b>SS</b> = 2 N/O contacts <b>SC</b> = 1 N/O contact/ 1 NC contact <b>C0</b> = 1 NC contact <b>CC</b> = 2 NC contacts <b>E0</b> = 1 electr. cont. <b>EE</b> = 2 electr. cont.		
20 - 150	KSK - 1150...	KSK - 2150...					
30 - 200	KSK - 1200...	KSK - 2200...					
30 - 300	KSK - 1300...	KSK - 2300...					
50 - 500	KSK - 1500...	KSK - 2500...					
100 - 1000	KSK - 1999...	KSK - 2999...					
						<b>K32</b> = PVC-glue-in connection Ø 32 <b>V32</b> = PVDF –Welding sleeve Ø 32* <b>P15</b> = PVC G 1/2 female <b>P20</b> = PVC G 3/4 female <b>P25</b> = PVC G 1 female <b>T25</b> = Cast iron G 1 female	<b>00</b> = without contact <b>S0</b> = 1 N/O contact <b>SS</b> = 2 N/O contacts <b>SC</b> = 1 N/O contact/ 1 NC contact <b>C0</b> = 1 NC contact <b>CC</b> = 2 NC contacts <b>E0</b> = 1 electr. cont. <b>EE</b> = 2 electr. cont.

## 12. Dimensions

Dimensions (with standard glue-in conn. PVC, PVC G 1/4 female or PVDF welding sleeve)

Model	DN	da	L	L1	L2	D	G**	Press. loss mm WC*
KSK-..015..	10	16	165	171	199	35	G 3/4	46
KSK-..025..	10	16	165	171	199	35	G 3/4	46
KSK-..050..	10	16	165	171	199	35	G 3/4	46
KSK-..080..	15	20	185	191	223	43	G 1	45
KSK-..100..	10	16	165	171	199	35	G 3/4	46
KSK-..150..	15	20	185	191	223	43	G 1	45
KSK-..200..	15	20	185	191	223	43	G 1	45
KSK-..300..	25	32	200	206	250	60	G 1 1/2	83
KSK-..500..	25	32	200	206	250	60	G 1 1/2	83
KSK-..990..	25	32	200	206	250	60	G 1 1/2	83

\*Medium water \*\*without auxiliary thread fitting

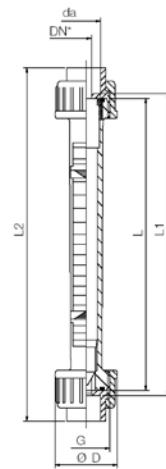

Dimensions (with special thread fittings in brass or stainless steel) female or male

Model	L	L2	Special thread fitting		SW	G**	Press. loss mm WS*
			Female	Male			
KSK-..015..	165	-	-	-	-	G 3/4	46
KSK-..025..	165	-	-	-	-	G 3/4	46
KSK-..050..	165	-	-	-	-	G 3/4	46
KSK-..080..	185	245	G 1/2	G 1/2 or G 3/4	36	G 1	45
KSK-..100..	165	-	-	-	-	G 3/4	46
KSK-..150..	185	245	G 1/2	G 1/2 or G 3/4	36	G 1	45
KSK-..200..	185	245	G 1/2	G 1/2 or G 3/4	36	G 1	45
KSK-..300..	200	-	-	-	-	G 1 1/2	83
KSK-..500..	200	-	-	-	-	G 1 1/2	83
KSK-..990..	200	-	-	-	-	G 1 1/2	83

\*Medium water \*\*without auxiliary thread fitting

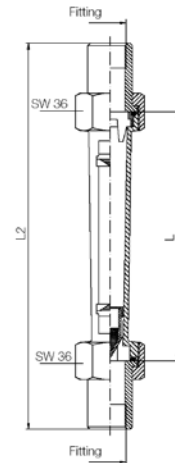

Dimensions (with special thread fittings made of PVC or Cast iron) female

Model	L	L2	Special thread fitting	SW/D	Male**	Press. loss mm WC*
KSK-..300..	200	295	PVC, G 1/2 female	Ø 60	G 1 1/2	83
KSK-..300..	200	303	PVC, G 3/4 female	Ø 60	G 1 1/2	83
KSK-..300..	200	346	PVC, G 1 female	Ø 60	G 1 1/2	83
KSK-..500..	200	255	Cast iron G 1 female	SW 55	G 1 1/2	83
KSK-..500..	200	295	PVC, G 1/2 female	Ø 60	G 1 1/2	83
KSK-..500..	200	303	PVC, G 3/4 female	Ø 60	G 1 1/2	83
KSK-..500..	200	346	PVC, G 1 female	Ø 60	G 1 1/2	83
KSK-..999..	200	255	Cast iron G 1 female	SW 55	G 1 1/2	83
KSK-..999..	200	295	PVC, G 1/2 female	Ø 60	G 1 1/2	83
KSK-..999..	200	303	PVC, G 3/4 female	Ø 60	G 1 1/2	83
KSK-..999..	200	346	PVC, G 1 female	Ø 60	G 1 1/2	83

\*Medium water \*\*without auxiliary thread fitting

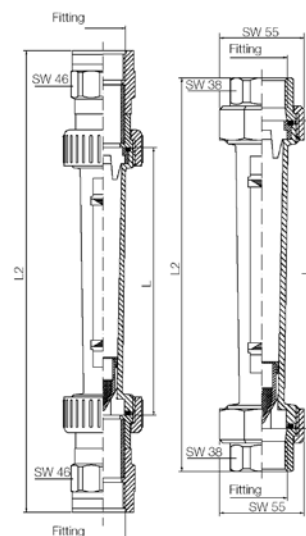

## 13. Disposal

### Note!

- Avoid environmental damage caused by media-contaminated parts
- Dispose of the device and packaging in an environmentally friendly manner
- Comply with applicable national and international disposal regulations and environmental regulations.

### Batteries

Batteries containing pollutants are marked with a sign consisting of a crossed-out garbage can and the chemical symbol (Cd, Hg, Li or Pb) of the heavy metal that is decisive for the classification as containing pollutants:

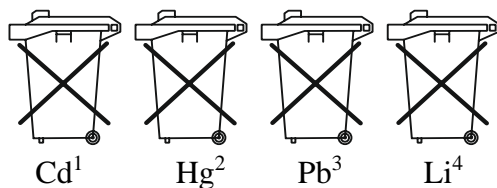

1. „Cd" stands for cadmium
2. „Hg" stands for mercury
3. „Pb" stands for lead
4. „Li" stands for lithium

### Electrical and electronic equipment

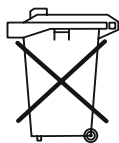

## 14. EU Declaration of Conformance

---

We, KOBOLD Messring GmbH, Hofheim-Ts, Germany, declare under our sole responsibility that the product:

**Plastic Flow Meter                      Model: KSK-...**

to which this declaration relates is in conformity with the standards noted below:

**EN 61000-6-3:2011**

Electromagnetic compatibility (EMC) - Part 6-3: Generic standards - Emission standard for residential, commercial and light-industrial environments

**EN 61010-1:2010**

Safety requirements for electrical equipment for measurement, control and laboratory use - Part 1: General requirements

**EN 60529:2014**

Protection through housing (IP-Code)

**EN IEC 63000:2018** Technical documentation for the assessment of electrical and electronic products with respect to the restriction of hazardous substances

Also, the following EC guidelines are fulfilled:

<b>2014/30/EU</b>	<b>EMC Directive</b>
<b>2014/35/EU</b>	<b>Low Voltage Directive</b>
<b>2011/65/EU</b>	<b>RoHS (category 9)</b>
<b>2015/863/EU</b>	<b>Delegated Directive (RoHS III)</b>



H. Peters  
General Manager



M. Wenzel  
Proxy Holder

Hofheim, 25 March 2021

## 15. UK Declaration of Conformity

---

We, KOBOLD Messring GmbH, Hofheim-Ts, Germany, declare under our sole responsibility that the product:

**Plastic Flow Meter                      Model: KSK-...**

to which this declaration relates is in conformity with the standards noted below:

**BS EN 61000-6-3+A1:2007**

Electromagnetic compatibility (EMC). Generic standards. Emission standard for residential, commercial and light-industrial environments

**BS EN 61010-1:2010+A1:2019**

Safety requirements for electrical equipment for measurement, control, and laboratory use. General requirements

**BS EN 60529:1992+A2:2013**

Degrees of protection provided by enclosures (IP Code)

**BS EN IEC 63000:2018**

Technical documentation for the assessment of electrical and electronic products with respect to the restriction of hazardous substances.

Also, the following UK guidelines are fulfilled:

<b>S.I. 2016/1091</b>	Electromagnetic Compatibility Regulations 2016
<b>S.I. 2016/1101</b>	Electrical Equipment (Safety) Regulations 2016
<b>S.I. 2012/3032</b>	The Restriction of the Use of Certain Hazardous Substances in Electrical and Electronic Equipment Regulations 2012

Hofheim, 25 March 2021



H. Peters  
Geschäftsführer



M. Wenzel  
Prokurist