



## OPERATING DATA

<b>Medium Temp. Max</b>	0°C...+70°C -20°C...+180°C as optional
<b>Ambient Temperature</b>	-30°C...+70°C
<b>Mounting Joint</b>	Flanged DIN/ ANSI,BS,DIN 11 851 for Food as optional
<b>Standart pressure</b>	PN6,PN10,PN16,PN40
<b>Excitation coil insulation</b>	E
<b>Control principle</b>	DC pulse
<b>Enclosure</b>	IP67 for EMDE-CM,IC,TR/ IP68 as optional IP68 for EMDE-RM
<b>Special Design</b>	Unit for explosion hazard environment- Zone 2
<b>Accuracy</b>	±0,5 of measured value ±0,2 as optional

## MEASURING RANGES

**Pipe Size Range** DN10...DN2200

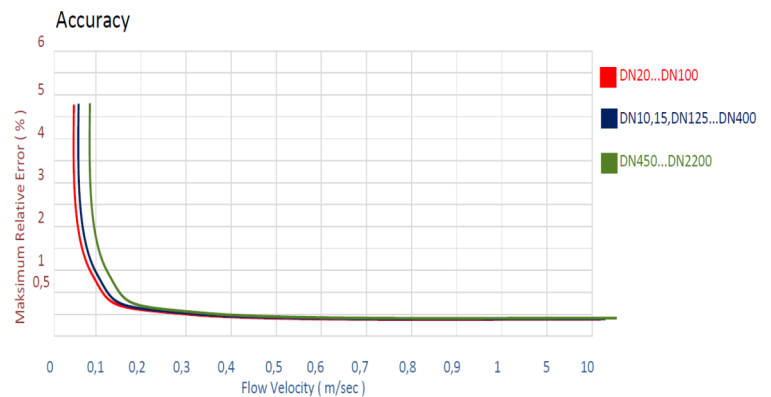

## MATERIALS

<b>Measuring tube</b>	Stainless Steel
<b>Sensor cover</b>	Carbon Steel Stainless Steel as optional
<b>Flange</b>	Carbon Steel Stainless Steel as optional
<b>Sensing electrode</b>	Stainless Steel AISI316L/ Titanium, Hastelloy-B, Hastelloy-C, Platinum,Tantalum Nickel alloy as optional
<b>Lining</b>	Hard Rubber / Soft Rubber, PTFE, PE, PFA as optional

## PRODUCT CLASSIFICATION



COMPACT/ EMDE-CM

REMOTE/EMDE-RM

BATTERY POWERED  
/EMDE-BT

COMPACT INFRARED  
CONTROL/EMDE-IC

TRANSMITTER/EMDE-TR

# TECNICAL DRAWING AND DIMENSIONS

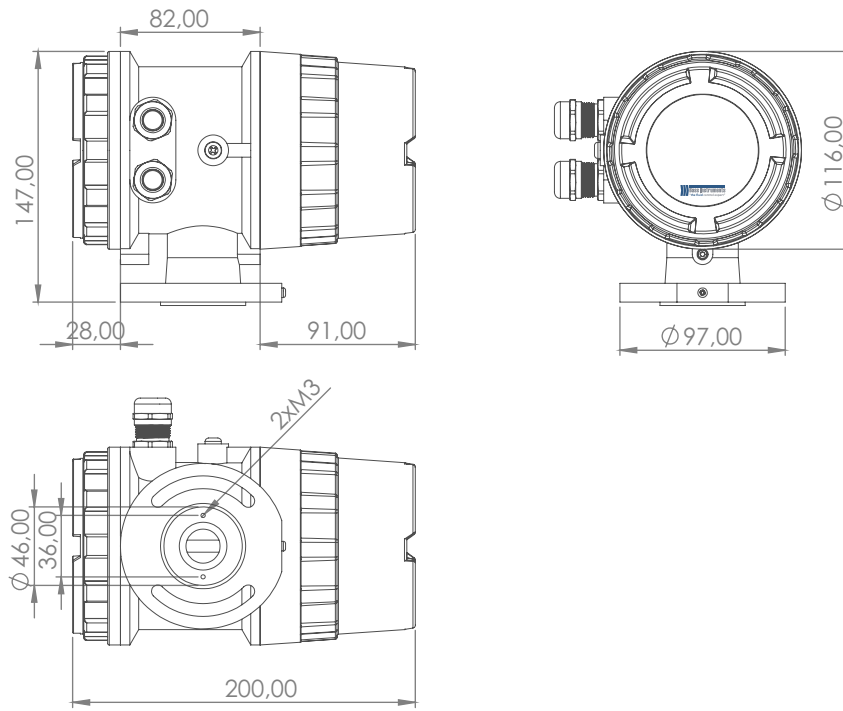

EMD-CM/EMD-IC HEAD

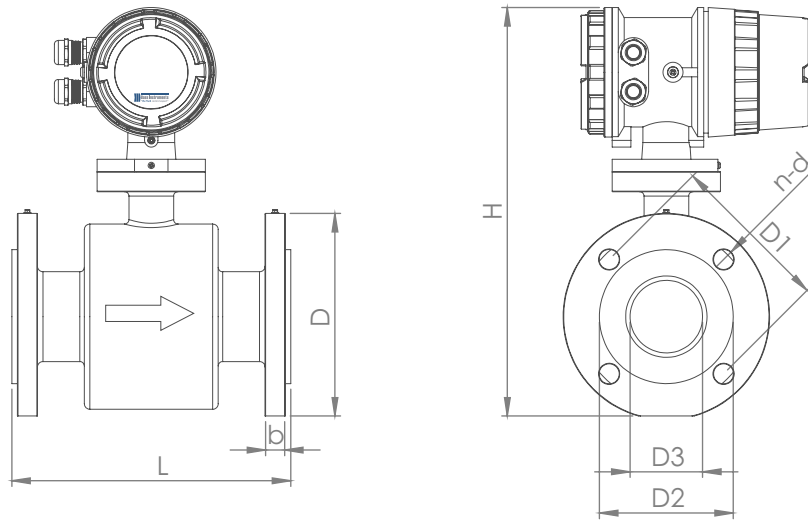

EMD-CM (Compact)

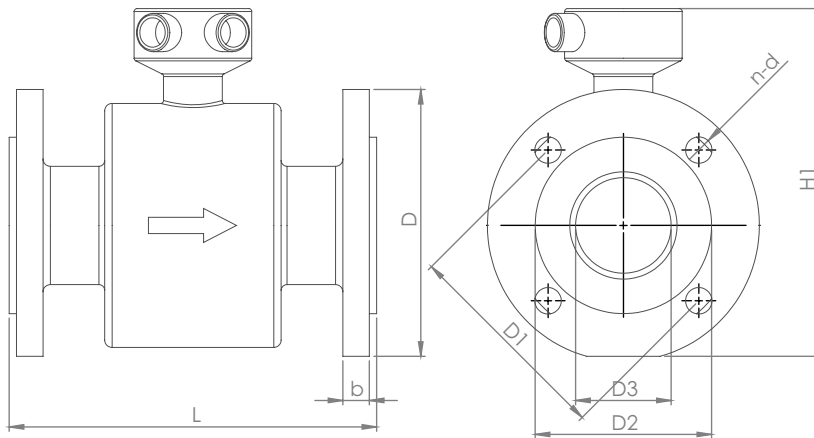

EMD-RM (Remote)

Diameter	Pressure Rating (Bar)	H	H1	L	D	D1	n-d	b
10-15	40	260-310	190-240	200	90-95	60-65	4xø14	14
20	40	315	245	200	105	75	4xø14	16
25	40	325	255	200	115	85	4xø14	16
32	40	325	255	200	140	100	4xø18	18
40	40	340	270	200	150	110	4xø18	18
50	40	355	285	200	165	125	4xø18	19
65	16	375	305	200	185	145	4xø18	20
80	16	385	315	200	200	160	8xø18	20
100	16	415	345	250	220	180	8xø18	22
	25	415	345	250	235	190	8xø22	24
125	16	445	375	250	250	210	8xø18	22
	25	445	375	250	270	220	8xø26	26
150	16	475	405	300	285	240	8xø22	24
	25	475	405	300	300	250	8xø26	28
200	16	505	435	350	340	295	12xø22	26
	25	505	435	350	360	310	12xø26	30
250	16	590	520	450	405	355	12xø26	29
	25	590	520	450	425	370	12xø30	32
300	16	645	575	500	460	410	12xø26	32
350	10	695	625	550	505	460	16xø22	28
400	10	745	675	600	565	515	16xø26	32
450	10	825	755	600	615	565	20xø26	36
500	10	878	808	600	670	620	20xø26	38
600	10	988	918	600	780	725	20xø30	42
700	10	1095	1025	700	895	840	24xø30	36
800	10	1208	1138	800	1015	950	24xø34	36
900	6	1310	1220	900	1075	1020	24xø30	38
1000	6	1413	1323	1000	1175	1120	28xø30	38
1200	6	1525	1435	1200	1405	1340	32xø33	36
1400	6	1735	1645	1400	1630	1560	36xø36	36
1600	6	1965	1875	1600	1830	1760	40xø36	36
1800	6	2155	2065	1800	2045	1970	44xø39	36
2000	6	2365	2275	2000	2265	2180	48xø42	36

\*Dimension unit is mm

## MEASURING RANGES

DN (mm)	Flow Range (L/s)		Flow Range (m³/h)		Ordering Code
	Qmin	Qmax	Qmin	Qmax	
10	0,0078	0,785	0,0282	2,827	0010
15	0,0176	1,767	0,0636	6,361	0015
20	0,0314	3,141	0,1130	11,3	0020
25	0,0490	4,908	0,1767	17,67	0025
32	0,0804	8,042	0,2895	28,95	0032
40	0,1256	12,56	0,4523	45,23	0040
50	0,1963	19,63	0,7068	70,68	0050
65	0,3318	33,18	1,194	119,4	0065
80	0,5026	50,26	1,809	180,9	0080
100	0,7853	78,53	2,827	282,7	0100
125	1,227	122,7	4,417	441,7	0125
150	1,767	176,6	6,361	636,1	0150
200	3,141	314,1	11,30	1130	0200
250	4,908	490,8	17,67	1767	0250
300	7,068	706,8	25,44	2544	0300
350	9,621	962,1	34,63	3463	0350
400	12,56	1256	45,23	4523	0400
450	15,90	1590	57,25	5725	0450
500	19,63	1963	70,68	7068	0500
600	28,27	2827	101,7	10178	0600
700	38,48	3848	138,5	13854	0700
800	50,26	5026	180,9	18095	0800
900	63,61	6361	229	22902	0900
1000	78,53	7853	282,7	28274	1000
1200	113,09	11309	407,15	40715	1200
1400	153,93	15393	554,17	55417	1400
1600	201,06	20106	723,82	72382	1600
1800	254,46	25446	916,08	91608	1800
2000	314,15	31415	1130,97	113097	2000
2200	380,13	38013	1368,47	136847	2200

\*According to 0,1...10 m/sec.

# ELECTRICAL DATA

<b>Medium Electric Conductivity</b>	≥5 μS/cm / ≥20 μS/cm for de-mineralised water
<b>Input Resistance</b>	10 <sup>10</sup> Ohms
<b>Measuring Accuracy</b>	±0,5 % of measured value between 0,1 and 10 m/sec, ±0,2 % as optional
<b>Analogue Output (active)</b>	4...20 mA/ 500 Ohms
<b>Impulse Output</b>	4(0) to 20 mA/ 500 Ohms
	Standard 0...1 kHz/ 0....10 kHz max. (30 V/20 mA/DC)
<b>Flow Direction Relay Module</b>	As optional
<b>Power Supply</b>	90-250V/ 50-60 Hz/ 10 VA 24V/ >0,5 A/DC
<b>Ambient temperature</b>	-20°C ... +70°C
<b>Calibration Certificate</b>	Three Point
<b>Others</b>	

Controller Variant	Specification	EMDE-RM	EMDE-CM	EMDE-IC	EMDE-TR
Measuring Filtration	Adjustable in multiple modes	☼	☼	☼	
Elimination of Small Flows	Adjustable by 0.1 %	☼	☼	☼	
Instant Flow	B-D(L/s, L/min, cu.m <sup>3</sup> /h, Ga/min, etc.)	☼	☼	☼	
Total Flow	Bi-directional (m <sup>3</sup> ,L, gallons)	☼	☼	☼	
Zero Flow	Automatic zero point set-up	☼	☼	☼	
Values Display	Graphic display, 132 × 64 pixels			☼	
	Alphanumeric LCD, 2 × 16 characters	☼	☼		
Set-up	Infrared contactless/Data			☼	
Optional Modes	Empty pipeline detection/Dosing	☼	☼	☼	
Alarm output 1	Selectable	☼	☼	☼	
Alarm output 2	Selectable	☼	☼	☼	
Enclosure	IP67	☼	☼	☼	
	IP68	☼			☼
Accessories	Infrared remote control			☼	

# COMMUNICATION

<b>On request</b>	RS 232
	RS 485
	HART DTM
	Modbus-RTU
	Profibus

# WIRING

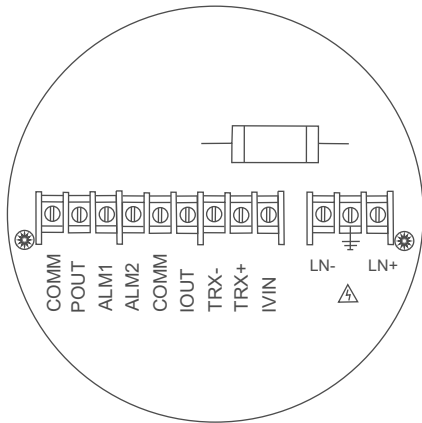

Compact Housing

POUT	Frequency(Pulse) Output for Bi-directional Flow
ALM1	Alarm Output for Upper Limit
ALM2	Alarm Output for Low Limit
COMM	Frequency, Pulse and Current Common (GND)
COMM	Frequency, Pulse and Current Common (GND)
IOUT	Current Output of Flow Rate
IVIN	24V DC Power Supply for 2-wire 4-20mA Output
TRX+	+Communication RS485(+)
TRX-	-Communication RS485(-)
LN+	L: Live Wire of 110-240Vac; +: 24V DC +
LN-	N: Naught Wire of 110-240Vac; -: 24V DC -

Note: Don't connect 110-240Vac Power on 221B converter which is DC Power Supply Type.

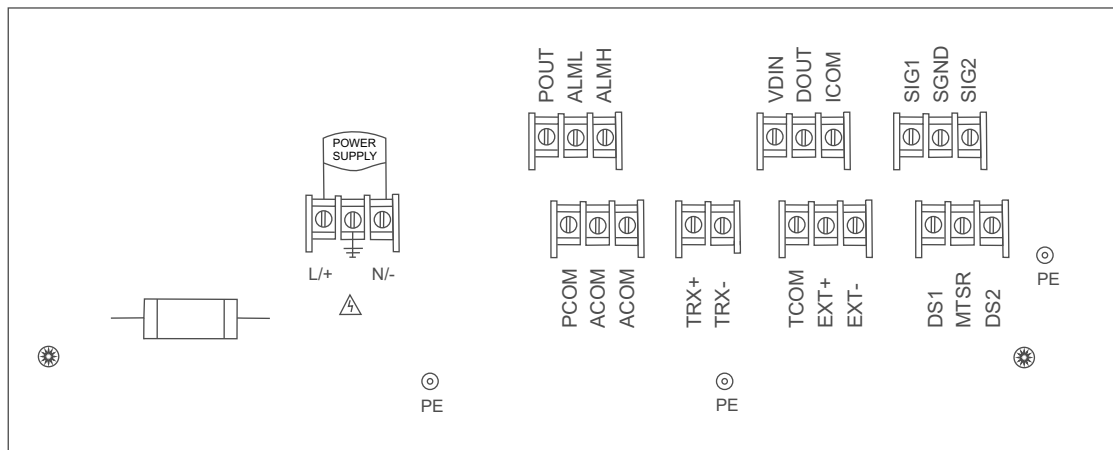

Pulse Output	POUT	Frequency(Pulse) Output for Bi- directional Flow
Alarm Output	ALMH	Alarm Output for Upper Limit
Alarm Output	ALML	Alarm Output for Low Limit
RS485 (Function Optional)	TRX+	Communication RS485(+ )
	TRX-	Communication RS485(-)
Analog Current Output	VDIN	24 VDC Power Supply for 2- wire 4- 20mA Output
Power Supply	IOUT	Analog Current Output
	ICOM	Analog Current Output Ground
	L/+	L: Live Wire of 110- 240Vac; +: 24V DC +
	N/-	N: Naught Wire of 110- 240Vac; -: 24V DC -
Signal from Sensor	SIG1	Signal 1
	SGND	Signal Ground
	SIG2	Signal 2
	TCOM	Reserved
	EXT+	Exciting Current+
	EXT-	Exciting Current-
	DS1	Shielded Exciting1
	MTSR	Reserved
	DS2	Shielded Exciting2

Note: Don't connect 110-240Vac Power on 221B converter which is DC Power Supply Type.

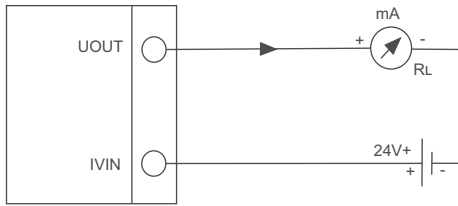

Current Output-Two wire connection

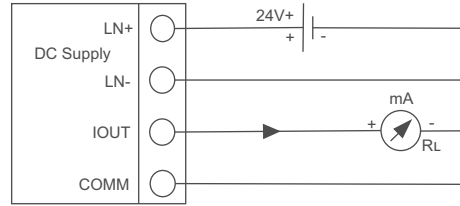

Current Output-Four wire connection(DC)

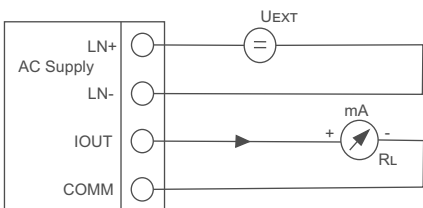

Current Output-Four wire connection(AC)

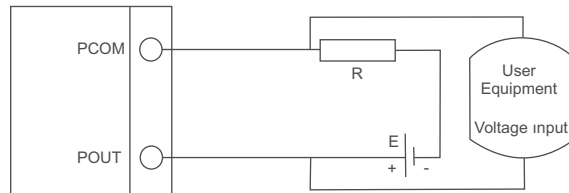

Digital Voltage Output

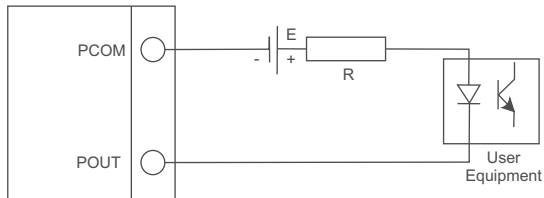

Digital Output To Photoelectricity Coupling

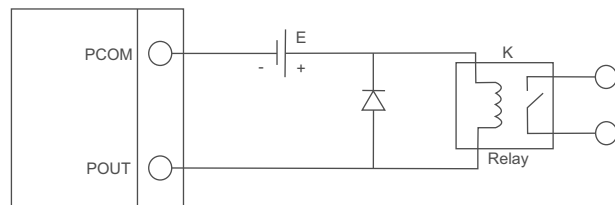

Digital Output To Relay

## APPROVAL

EN 61326-1 : 2013  
 EN 61326-2-3 : 2013  
 EN 61010-1 : 2011  
 ISO 9001 : 2015  
 PED Gr.1  
 IEC/EN 60529, LVD-656-02  
 ISO17025 Calibration Certificate  
 FieldComm Group membership



