

COMPACT ORIFICE FLOWMETER

FOFT-...

Housing : IP67
 Explosion Proof: Class I, Groups A, B, C, D;
 Class II, Groups E, F, G; NEMA4X



The Bass Instruments Compact Orifice Flowmeter Series is designed for closed loop control and general purpose monitoring applications. This design lowers the total installed cost of DP Flow measurement points eliminating the need for fittings, impulse tubing, valves, adapters and manifolds by providing a single device packaged together for simplified installation. By integrating Autrol pressure transmitters with the Compact Orifice primary element, we deliver the highest performing Flowmeters which arrive assembled, calibrated, pressure tested, and ready to install.

Features

- Volume or mass flow measurements
- Integrated counter
- Modular design concept
- High reproducibility
- No moving parts
- Extremely rugged and stable
- Suited also for extreme applications
- Dry calibration is possible (with reference to ISO 5167)
- Easy to install without pulse piping
- Simple change of measurement range

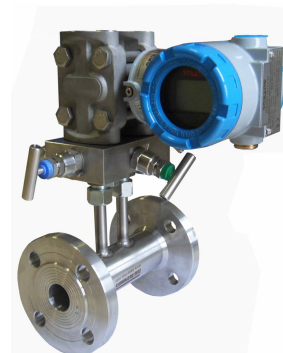

Applications

The measurement of flows is, in industry, one of the most demanding and complex tasks. Even today there does not exist a universal measuring instrument for all applications. Here both manufacturers and the users face the task selecting the right method of measurement for each application. Owing to their simplicity and reliability, flow meters operating according to the differential pressure method are rated highly. The compact design of the FOFT series results in considerable cost savings in the areas of fitting and maintenance. The FOFT compact orifice is used in many branches of industry for the purpose of measuring the flow of liquids, gases and vapours.

- Use at locations where other principles of measurement fail or redundant use in series to instruments which are based on other principles (for example orifice and vortex meter or orifice and turbine)
- Use at locations which are exposed to considerable vibrations
- Flow measurement (volume/mass) for balancing (for example, steam measurements, heat carriers, chemical products ...)
- Process control

Measuring Principle

The principle of measuring the differential pressure is based on the fact that a differential pressure is created across that section of a pipe where its cross section is reduced. This is then taken as a measure for the flow. For the differential pressure produced (differential pressure p at the point where the pressure is read) and the flow q , the flowing equation applies:

$$q = k \cdot \sqrt{\Delta p}$$

This principle of measurement is so popular because related terms, definitions and equipment characteristics have been laid down by way of standards already at a very early stage. The agreement between theoretical calculations and measured values has been proven through comprehensive experiments. This has been the basis for wide-spread acceptance throughout the industry. Today, about 50% of all flow meters rely on the principle of measuring the differential pressure.

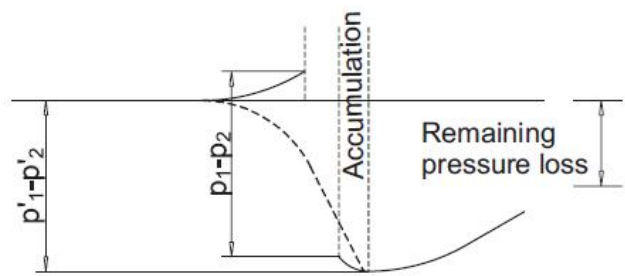
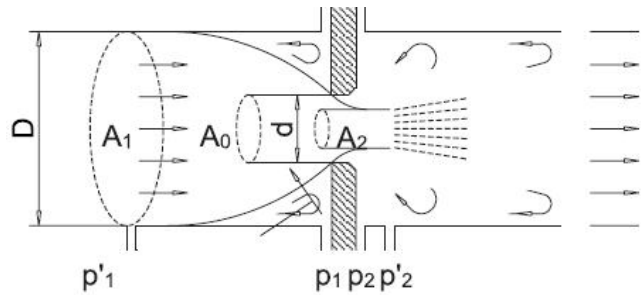

Pressure level in the middle of the pipe (dashed) at the wall of the pipe (solid)

Mounting Position

In general, the following needs to be observed:

- sufficiently long inlet and outlet
- avoidance of sudden changes in diameter
- no projecting welded seams
- direction of flow (also correct fitting of the orifice)
- correct gaskets which do not extend into the measurement chamber

Recommended fitting positions for:

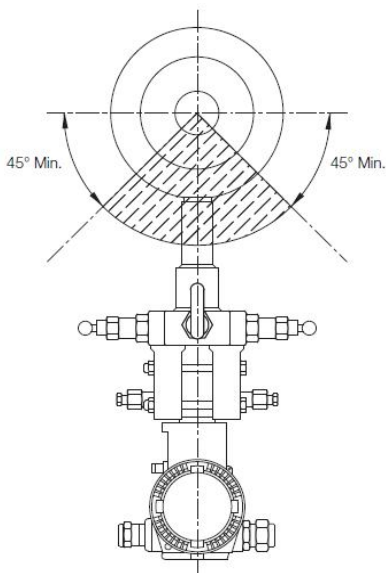

Horizontal Pipe Mounting – Liquids & Steam

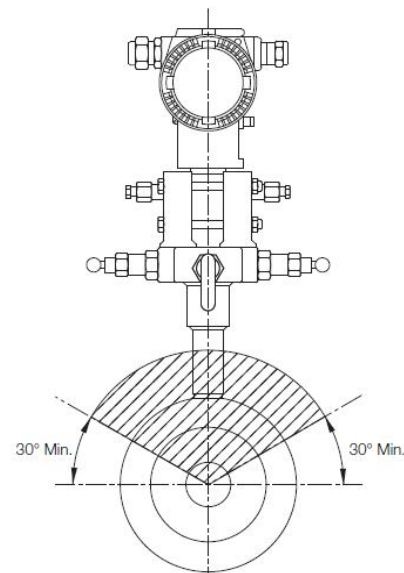

Horizontal Pipe Mounting – Gas

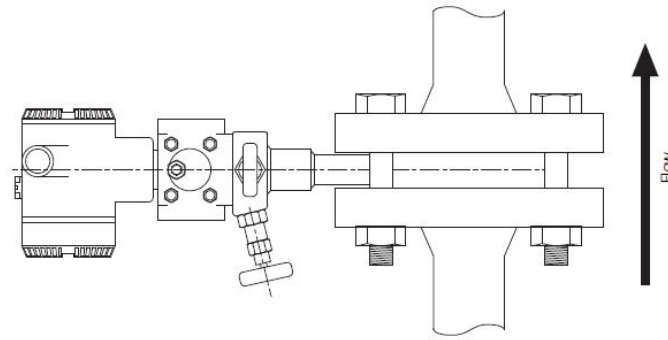

Vertical Pipe Mounting – Liquid, Gas and Steam (Upward Flow)

Specifications

| | |
|-------------------------------------|--|
| Measurement range | 1 - 150000 m ³ /h gas/vapour 0,2 - 9000 m ³ /h for liquids |
| Output | 4-20 mA, HART (Profibus, Field Bus upon request) pulse ops. |
| Deviation of the measurements | ± 0,8 % of meas. value for dry calibration (>= DN 50) ± 0,6 % of meas. value for wet calibration |
| Conditions of usage | as to the conditions of usage the guidelines of ISO 5167 must be taken in to account |
| Fitting position | horizontal or vertical |
| Ambient temperature limits | - 40 °C ... + 70 °C |
| Stocking temperature | - 40 °C ... + 85 °C |
| Humidity | 0-100% rel. humidity of the air |
| System of protection | IP67 |
| Temperature limits for the material | - 40 °C to + 1000 °C (depending on model) |
| Inlet and outlet | acc. to ISO 5167 |
| State of aggregate of the medium | for liquid, gaseous and vapour phase media |
| Viscosity | max. approx. 30 mPas (higher viscosities upon request) |
| Pressure loss | remaining pressure loss is calculated for each orifice (typical max. 150mbar) |
| Material Pressure sensor: | AISI316L (Hastelloy and others upon request) |
| Process connection | DN 10 - 250 (bis DN 1000 upon request, (other connections like ANSI can be specified) PN 40 (up to PN 325 upon request) |
| Electrical connection Power supply | 12...45 V DC, 2 wire system, ½" NPT |
| Display | five digit LC display, rate or total (optional) |
| Certificates and approvals | CE conformity Ex approvals in accordance with ATEX / FM / CENELEC / JIS / CSA / SAA |

Ordering

| FOFT. | | | | | | | | Description |
|-------------------|-----|----|---|----|---|----|--|--|
| Line Size | XXX | | | | | | | Please fill (015 for DN15 or 200 for DN200) |
| Connection | D | | | | | | | Thread (please specify NPT,G or BSP) |
| | F | | | | | | | Flanged (please specify DIN,ANSI)please specify rating |
| | W | | | | | | | Wafer Type |
| Output | A | | | | | | | 4-20 mA+HART 2 wire |
| | P | | | | | | | 4-20 mA+HART and pulse (50Hz max) |
| Body Material | | CS | | | | | | Carbon Steel |
| | | S4 | | | | | | AISI 304 Stainless Steel |
| | | S6 | | | | | | AISI 316 Stainless Steel |
| | | OD | | | | | | Other,please specify |
| Display | | | N | | | | | None |
| | | | R | | | | | 5 digit LCD for rate |
| | | | T | | | | | 5 digit LCD for rate and total (rotative) |
| Enclosure | | | | IP | | | | IP67 |
| | | | | AD | | | | ATEX,flame proof Eex d II C T6,T5 or T4 |
| | | | | AA | | | | ATEX,Intrinsic Safety Ex ia IIC T6 |
| | | | | FD | | | | FM & FM Canada Explosion proof |
| | | | | FA | | | | FM & FM Canada Intrinsic Safety |
| Temperature Range | | | | | N | | | -40...300°C |
| | | | | | M | | | -40...500°C |
| Media | | | | | | L | | Liquid |
| | | | | | | G | | Gas |
| | | | | | | S | | Steam |
| Flow Range | | | | | | XX | | Please specify separately |

