

TDAS TYPE TURBINE FLOW METERS



Description

The Bass Instruments Gas Turbine Flowmeter introduces a new concept in accurate gas flow measurement. It features a transducer that utilizes a lightweight, low inertia rotor to sense gas velocity. It offers an output frequency that has a linear relationship to gas velocity over a wide flow range.

The meter tracks the flow rate continuously, offers little resistance to flow and has a unique cartridge design that allows removal of all internal parts as one assembly. The meter exhibits little sensitivity to gas density above two atmospheres pressure. The low inertia of the rotor and vee bearings allows overranging of the meter to twice its rated capacity without damage for intermittent flow variations.

Designed for maximum life, carbide rotor shaft and bearings require no lubrication. The cartridge assembly makes replacement and inspection of parts easy. The meter is designed for installation between two flanges. The digital pulse output generated by the Gas Turbine Flowmeter can be fed to companion readout devices capable of providing direct measurement of flow rate and accumulated throughput. These measurements can be automatically pressure-and/or temperature-compensated to obtain volumetric measurements in standard units.

Operating Principle

Fluid entering the meter passes through the inlet flow straightener which reduces its turbulent flow pattern and improves the fluid's velocity profile. Fluid then passes through the turbine, causing it to rotate at a speed proportional to fluid velocity. As each turbine blade passes through the magnetic field at the base of the transducer, an AC voltage pulse is generated in the pick-up coil. These pulses produce an output frequency proportional to the volumetric flow through the meter.

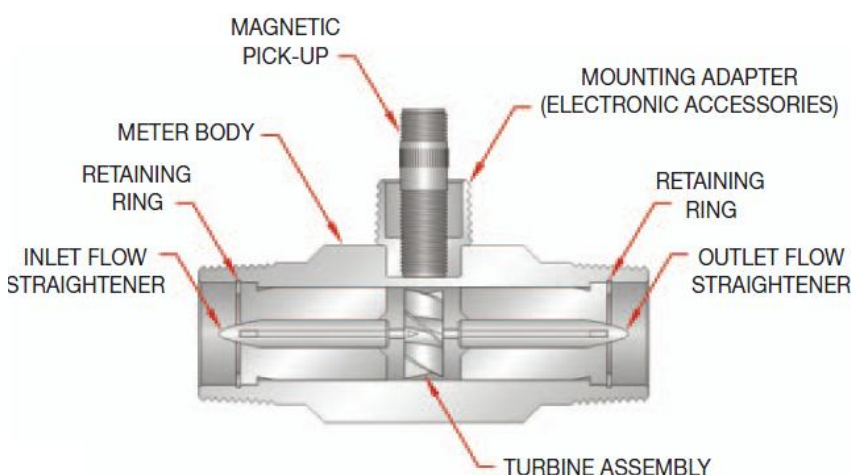

Features

- Flow ranges from 0,5 to 6500 Nm³/h
- Rugged stainless steel or aluminium construction
- Meter bore sizes from DN25 to DN300
- flange end connections DIN or ANSI
- Accuracy of $\pm 1,5\%$ of reading or $\pm 1\%$ on request
- Electronic integration available with LCD Flow Monitor, F to I Intelligent Converter or the K-Factor Scaler
- Standart Manufacturer Calibration Certificate
- Optional RS-485 communication
- Optional Battery Powered Display
- Optional pressure and temperature compensation



Pulse or Analog Output



LCD Display



Battery Powered or Compensation

Specifications

Materials of Construction	
Body	AISI 304 Stainless steel or Aluminium
Rotor	Anti-erosive ABS or Aluminium alloy
Rotor Support	AISI 316 Stainless steel
Turndown Ratio	10 : 1 standart , 20 : 1 or 30 : 1 on request
Accuracy	±1,5% of reading, ±1 on request
Repeatability	±0,1%
Calibration	Standart Manufacturer Calibration Certificate
Pressure Rating	16 bar or 40 bar max.
Temperature	-30°C...80°C
End Connection	Flange DIN,ANSI,JIS or Threaded
Power Supply	12...24 VDC for pulse 24VDC for analog and LCD 3 VDC lithium battery for battery powered LCD
Protection	IP65
Hazardous Area	Ex d II B T6 on request

Type and Flow Rate Tables (1)

Type	End Connection	StandartFlow Range m3/h	Max.Working Pressure
TDAS.025.S0	DN25	2...25	40
TDSS.040.S0	DN40	5...50	40
TDAS.050.S0	DN50	6,5...65	40
TDAS.050.S1		10...100	
TDAS.050.S2		15...160	
TDAS.080.S0	DN80	13...250	16
TDAS.080.S1		20...400	
TDAS.080.S2		32...650	
TDAS.100.S0	DN100	20...400	16
TDAS.100.S1		32...650	
TDAS.100.S2		50...1000	
TDAS.150.S0	DN150	32...650	16
TDAS.150.S1		50...1000	
TDAS.150.S2		80...1600	
TDAS.200.S0	DN200	80...1600	16
TDAS.200.S1		130...2500	
TDAS.200.S2		200...4000	
TDAS.250.S0	DN250	130...2500	16
TDAS.250.S1		200...4000	
TDAS.300.S0	DN300	200...4000	16
TDAS.300.S1		320...6500	

Installation

The Model TDAS Turbine Meter is simple to install and service. It operates in any orientation (horizontal to vertical) as long as the “flow direction” arrow is aligned in the same direction as the actual line flow. For optimum performance, the flow meter should be installed with a minimum of 10 diameters upstream straight pipe length and 5 diameters downstream straight pipe length.

Ordering

Ordering								Description
TDAS.								
Bore Sizes	XXX.XX							Please see “Type and Flow Rate Tables”
Connection		D						Thread (please specify NPT,G or BSP) 1” and 1 1/4”
		F						Flanged (please specify DIN,ANSI,JIS)
Converter Type			P					Pulse output
			A					4-20 mA output
			B					Lithium battery powered,with display,without output
			L					4-20 mA output,with display
			C					RS-485 communication,with display,24V DC
			H					Pressure and temperature compensation and 4-20mA, RS485 comm.
Accuracy Level				15				±1,5% of reading
				10				±1 % of reading
Turbine Material					S			Anti-corrosion ABS
					L			Aluminium alloy
Body Material						S		AISI 304 SS
						L		Aluminium alloy
Enclosure							N	IP65
							E	Ex d II B T6 flameproof